

SMART THINKING, THE WAY WE INNOVATE.



# CATTANI ASIA

2025 CATALOGUE

VALID TO 31 DECEMBER 2025



PAGE INTENTIONALLY BLANK

# CATTANI ASIA 2025 CATALOGUE – APPLICABLE REGIONS

PLEASE NOTE: Not all products are available in all countries.  
Please contact your local Business Development Manager for more information.



Philippines



Taiwan



**S**PECIALISTS IN AIR TECHNOLOGY,  
DRIVEN BY: IMAGINATION  
AND RESEARCH IN DESIGN,  
QUALITY IN PRODUCTION





### ITALIAN CRAFTSMANSHIP

Our premium air technology is the embodiment of everything that Cattani stands for. We feel a deep sense of pride when we deliver our creations, knowing its maximum reliability. Our excellent results may define us, but they also remind us of its origins – Parma, Italy.

### A REGION RENOWNED FOR QUALITY

Parma province is part of the Emilia-Romagna region, famously renowned for Parmigiano Reggiano cheese, Prosciutto di Parma, and the home of quality brands such as Ferrari, Lamborghini, Maserati, and Ducati.

Amongst the finest craftsmanship in the world, it was here that the late Prof. Augusto Cattani established Cattani in 1967 and pioneered the most advanced dental suction and air compression equipment.

After becoming a publicly limited company in 1981, Cattani S.p.A. expanded the range with the Magnolia dental consumables range, extending the group's air technology capabilities to chemical products.

Passing on the unparalleled quality and technical knowledge to the next generation of the family, Ennio Cattani, their legacy had reached partners in more than 60 countries. Among them, the Clark family in Melbourne, Australia.



## THE AUSTRALIAN LEGACY

The essence of Cattani quality was conceived in Italy and is now meticulously cultivated in the Australasian region. Our first-class service guarantees added value to the already unmatched workmanship brought to us by Italy, before delivering it to our customers. From our additional quality inspection on Australian soil, to our exclusive After Care Scheduled Service and Blueprints Training programs, we go the extra mile to strive towards achieving 100% reliability.

As in Italy, Cattani Australia is very much a family affair. Bill Clark, who founded Cattani Australia in 1987, started working in the dental industry more than 50 years ago. Bill holds a Non-Executive Board Position and is a Director, and is actively involved within the global dental industry as chair of the International Organization for Standardization (ISO) Committee.

The family's ongoing contributions extend to Bill's wife, Pam Clark, former Federal ADIA President 2006 to 2010, who was admitted as an Officer of the Order of Australia in 2017, cited for her 'Contribution to Humanity' after dedicating 6 years working with the United Nations and World Health Organisation, in development of The Minamata Treaty. Pam today actively holds roles with FDI and a Board Position on Academy of Dentistry International Foundation.

The next generation of the Clark family has also mirrored the Italian generational business tradition. In 2015, Allison Clark took up a Director and Board Position in the Company, relieving Bill after over 50 years of service. From this Board position, Allison has worked with Cattani Italy to expand the Cattani Agency into South East Asia, to grow on and from the Family legacy in Australia and New Zealand. Allison remains working an active and important strategic role from the Board.

Today, the Cattani-ESAM group specialises in premium air technology across the Asia Pacific region, under the leadership of Chief Executive Officer, Greg Fox. With 30 years' experience in the dental industry, including roles as Director of Marketing and Vice-President / General Manager of Dentsply, Greg drives company success through existing Cattani values, yet accelerates innovation to lead the way in premium air technology.

Leveraging our strong technical team and their commitment to innovation through in-house training and e-learning platform, the Cattani group of companies is well placed to continue to expand across the Asia Pacific region and set the quality benchmark in the global dental industry.

- **1967**  
Cattani is established.
- **1981**  
Cattani becomes a publicly limited company.
- **1987**  
Cattani Australia is established.
- **1993**  
NASA appoints Cattani-ESAM as compressor supplier.
- **c. 1997**  
Eurostar Italia train pressurisation project.
- **2003**  
Magnolia range launched.
- **2005**  
SMART Suction introduced.
- **2015**  
SMART Cube range introduced.
- **2019**  
Blueprints training program.
- **2020**  
ADIA Education Award.
- **2022**  
Turbo SMART HP launched.
- **2023**  
AFTER CARE Online launched.



*“All this painstaking care for our work. . . are justified by the results achieved. Quality needs to be sought with determination and must be scrupulously adhered to thereafter. We cannot afford to stop, as progress is unstoppable.”*

Prof. Augusto Cattani, Founder of Cattani

### QUALITY – AIR TECHNOLOGY SPECIALISTS

The ownership of Cattani equipment makes a bold statement about the dental care professionals: They are quality driven and have the highest expectations for optimal performance, precision, and reliability.

#### INNOVATION

Innovation goes hand in hand with quality. Cattani Italy prides itself in a long history of “intelligent” suction systems and compressors, from automatic operation to variable motor speed, intuitive power output (inverter control), noise reduction, and the development of suction system with a 50% reduction on raw materials.

At Cattani Australasia, we follow the Cattani Italy example, but we also take initiative. We not only lead the way in modular installation of parallel units, but with an internal technical team we can promptly respond to market demands with in-house product development.

#### EXPERTISE

We are the avant-garde, the resilient, the relentless, who are passionate about innovation and breaking new ground. With more than 50 years in the business, hailing from region of engineering excellence, the home of Ferrari engineering, Cattani has built a global reputation in its world class craftsmanship. Don't just take our word for it. The Cattani-ESAM group was commissioned to supply air compression technology on the NASA space shuttle and the pressurisation of Eurostar Italia trains.

Cattani quality doesn't just happen. It is developed and meticulously refined over time, as Cattani leaves nothing to chance. When we specialise in one field only – air technology, the expected result is precision and mastery.

#### SERVICE

Cattani truly believes in overperforming to reach a superior level of distinction. Our commitment to equipment reliability is demonstrated through our quality assurance inspection at our Italian manufacturing facility.

This level of exclusivity is reinforced by our in-house local technical team, the frontrunners of the company who developed our After Care Scheduled Service and Blueprints training programs.

#### PERFORMANCE

Human centricity is key. We think and work in a holistic manner to create genuine benefits for our customers. Our 3-year warranty in compressors, means a peace of mind knowing your surgery has the support of our in-house technical team.

With energy savings of between 30 percent and 50 percent, a reduction in half the perceived noise through our acoustic housing, our ISO certified air solutions offer precision in dentistry, where it is paramount. Therefore, you can expect precision as an integral part of Cattani performance.





Quality and precision in air technology is the cornerstone of our values, and it is deep-rooted in the pride of Italian quality performance. It is no wonder Ferrari Engineering approached us for what was to become one of our most important ventures.

Our involvement in the space project began in the spring of 1993, when the late Professor Augusto Cattani was approached about the possibility of building a miniature compressor to be installed on board the NASA space shuttle.

With a limited storage space of merely a few centimetres, Ferrari Engineering as the supplier to the European Space Agency, recognised the enormous challenge for us, but showed absolute confidence and support in our capabilities.

Ultimately, the European Space Agency appointed the group to build a small-scale 180gm compressor, capable of maintaining a high pressure of 38 bar. The success of the NASA project sets the benchmark for Cattani, to deliver world class air technology to your dental practice.





In this fast-moving world, there is constant pressure to improve. Thankfully, we specialise in pressure, which is evident in our partnership with Eurostar Italia (formerly Pendolino Rail).

Known for their tilting train technology, their carriages can tilt at the bends at high speeds, hence the name 'Pendolino', meaning small pendulum in Italian.

During the planning for the pressurisation of their high-speed train, many tenders were submitted by major national and international companies. But the one that came out victorious, was none other than the Cattani-ESAM group.

Since then, we have developed successful partnerships globally, due to our unparalleled focus on delivering premium air technology. We don't fall under pressure, we evolve.



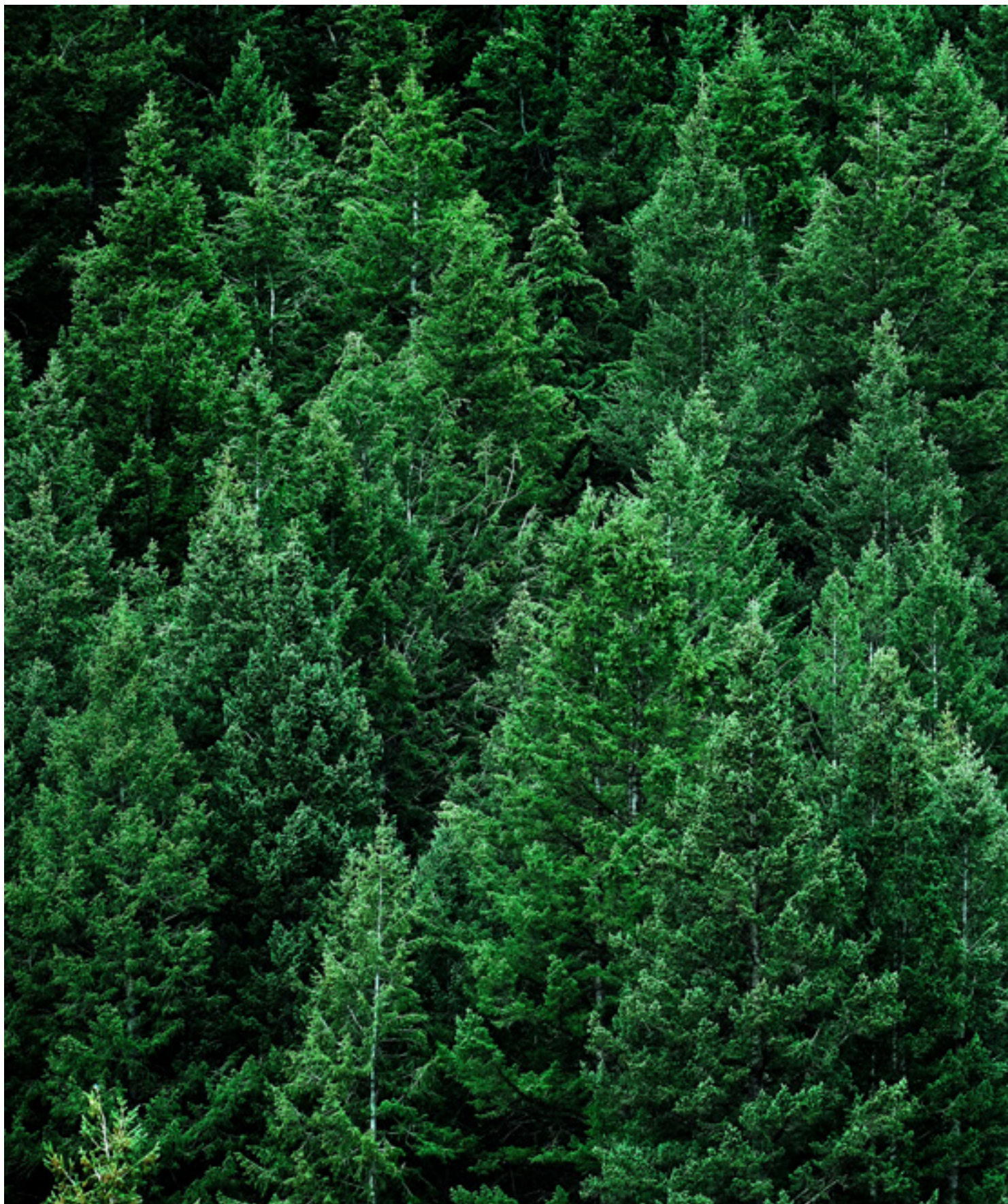



### COMPRESSORS

Introduction	10
Products	12

### COMPRESSORS – LARGE PLANT

Introduction	22
Products	24

### COMPRESSORS – CAD/CAM

Introduction	28
Products	30

### COMPRESSOR ACCESSORIES

Compressor Accessories	39
Compressor Spare Parts	40

### SMART SUCTION

Introduction	42
SMART Cube	44
Inverter Technology	45
Amalgam Retention	46
Products	47

### LARGE PLANT SOLUTIONS

Introduction	68
Products	70

### COMPACT PLANT SOLUTIONS

Introduction	78
Products	80

### CLASSIC SUCTION

Introduction	82
Products	83

### WET SUCTION

Products	90
----------	----

### SUCTION ACCESSORIES

Suction Accessories	94
Suction Spare Parts	110



### CONSUMABLES – MAGNOLIA

Introduction	120
Products	122

### MAINTENANCE, SERVICE AND INSTALLATION

Introduction	124
Equipment Installation	126

## PRODUCT SELECTION GUIDE

	1-2 CHAIRS	2-3 CHAIRS	3-4 CHAIRS	5-6 CHAIRS	7-8 CHAIRS	12+ CHAIRS
 COMPRESSORS	PAGE 12-13 PAGE 80	PAGE 14-15 PAGE 80	PAGE 16-17 PAGE 80	PAGE 18-19	PAGE 20-21	PAGE 24-27
 SUCTION	PAGE 47-50 PAGE 80	PAGE 51-54 PAGE 80	PAGE 55-63 PAGE 80	PAGE 64-65	PAGE 66-67	PAGE 70-77

\* Product selection is provided as a guide only. To determine the requirements of your dental clinic, contact our customer service and technical team.

Cattani Asia has a commitment to innovation and as such we reserve the right to change product specifications without notice. Please refer to our website for the most current product specifications. Product images and packaging are for illustrative purposes only, variations can occur due to the printing process of colours therefore the product you receive may not exactly correspond to the image.



# OIL-FREE DENTAL COMPRESSORS



## PURE RELIABILITY

Cattani users make a bold statement with their purchase: they have the highest expectations for quality, performance, precision, and reliability. This is a purchasing decision that we would always want you to reflect on with complete satisfaction.

To guarantee that, we provide you a 3-year warranty on our compressors.

### MORE THAN 50 YEARS IN PREMIUM AIR TECHNOLOGY

With more than 50 years of innovative contributions to the global dental industry, we provide expertise and specialisation in air technology.

### IT'S NOT JUST EQUIPMENT, IT'S AN INVESTMENT

We believe in our equipment so much that we offer a 3-year warranty on all our compressors. We'll take the chance, so you don't have to.

### DENTAL GRADE HYGIENE

Cattani compressors produce quality dental grade air by removing 99.975% of particles down to 0.3 micron. Air is then preserved in a dual coated compressor tank lined with a food grade resin and Biocote® silver ion for antimicrobial protection. Cattani compressed air quality is supported by an ISO 8573-1 standard compliance with Class 1:4:2.

### RELIABLE CATTANI COMMITMENT

We are committed to our customers enjoying their Cattani experience, from their first meeting with representatives, through technical advice before purchase, then ongoing support throughout the life of their asset.

### FUTUREPROOF CAPABILITIES

From a single chair right through to large-scale hospital and university installations, Cattani manufactures compressors in sizes and configurations suitable for every scenario.

### NOISE REDUCTION OPTIONS AVAILABLE

Where space is valuable and limited, noise can be an issue. For that, we offer a range of noise reduction options, from acoustic hoods to fully enclosed acoustic and temperature controlled cabinets.





## PERFECTING DENTAL GRADE AIR DELIVERY

No matter how sophisticated our equipment are, it only makes sense to us if it produces quality results. We believe delivering dental grade quality air is a journey of innovation and improvement, hence we have spent more than 50 years meticulously refining each step of this process.



STANDARD IN ALL AC COMPRESSORS WITH DRYER

HEPA H14 DRYER FILTER

### 1 IT STARTS WITH THE COMPRESSOR HEAD FILTER

The primary filter ensures long-term reliability of the head unit and pistons. This component alone removes dust and particles down to 20 micron. The good news is, we're just getting started.

### 2 PIONEERING CYCLONE TECHNOLOGY

As one of the pioneers in cyclone technology within dental systems, Cattani use a highly engineered design to remove condensation and water from the air. This initiates the two-stage process in producing dry air.

### 3 ADDED FILTRATION FOR SUPERIOR QUALITY

For enhanced fine particle separation, a secondary filter disc is added to remove additional fine particles as the air exits the cyclone.

### 4 DESICCANT DRYING FOR OPTIMAL DEW POINT

The desiccant drying column uses an energy efficient passive process to absorb any remaining moisture present in the air. This final drying process ensures a humidity class 4 in line with ISO 8753-1 as stated in ISO 22052.

### 5 SINTERED BRONZE FILTER FOR ZERO MAINTENANCE

The sintered bronze filter element acts as a prelude to the HEPA H14 filter, prolonging the life of the component. More good news - the sintered bronze filter never needs replacing or cleaning.

### 6 99.975% EFFICIENCY ISO STANDARD RATING

Our antibacterial High Efficiency Particulate Air (HEPA H14) filter removes 99.975% of all particles down to 0.3 micron, before preserving the air in the Biocote® and food grade resin protected tank, ready for use.

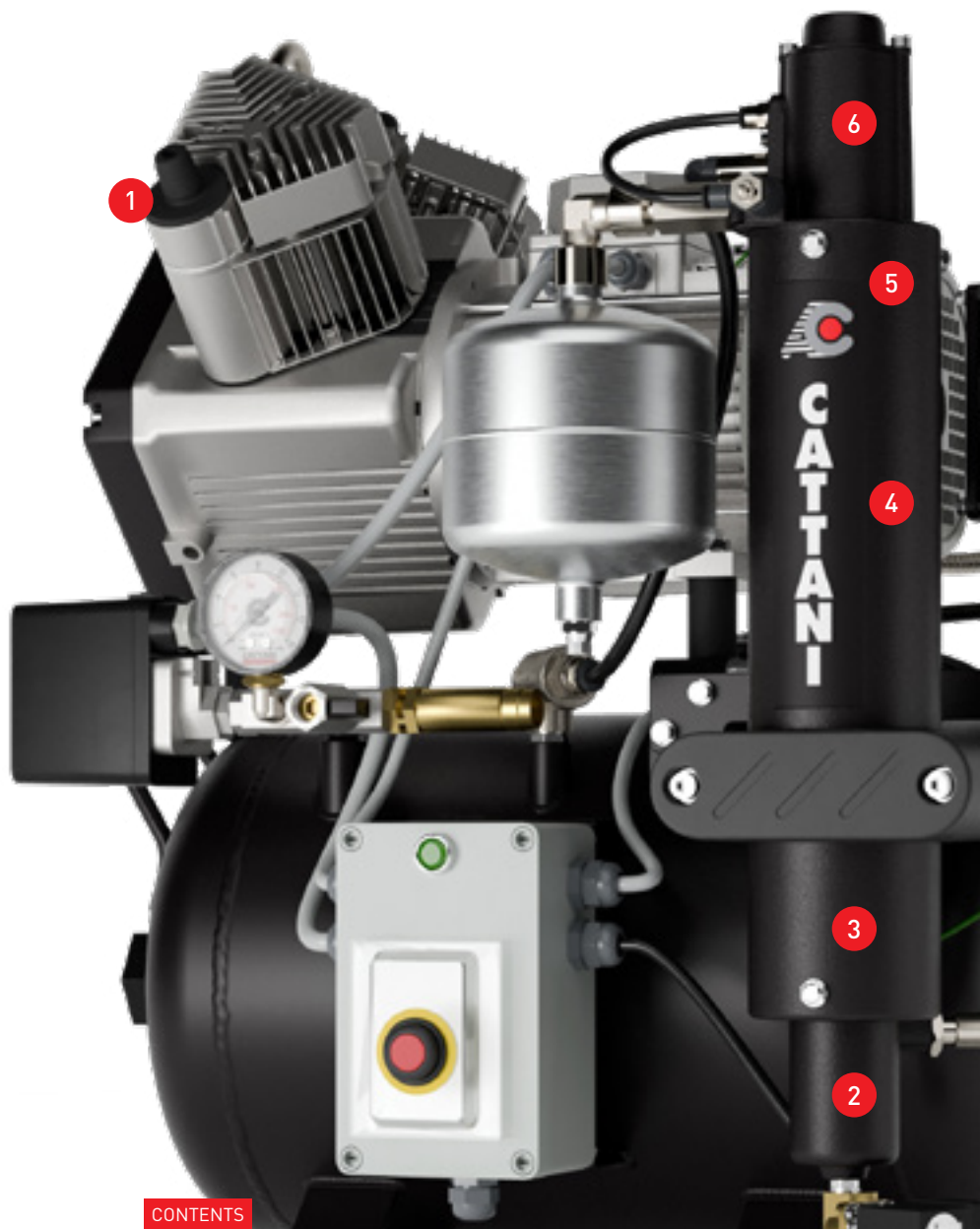

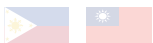

## DENTAL COMPRESSORS

### AC100 Single Cylinder Oil-free Dental Compressor | 1 chair

The most compact of our high-performance dental compressor range, the AC100 is designed to serve 1 chair. Cattani compressors are oil-free and rigorously tested to consistently deliver clean, dry, and hygienic air.

#### Details That Matter

- 3-year warranty
- Certified food grade resin coated tank
- Added antimicrobial protection with Biocote® silver-ion lining in tank
- Noise reduction option available (see AC100Q)
- Unrivalled technical service back-up



AC100	
Single Cylinder Oil-free Dental Compressor	
Item Code	013106
SPECIFICATIONS	
Power	60 HZ 0.7kW 4.9A 1PH 220V
Sound Output dB(A)	70
Max Air Flow at 5 Bar NI/min	67.5
Tank Size litres	30
Pressure Vessel	CE Certified
DIMENSIONS	
Height mm	720
Width mm	620
Depth mm	460
Weight kg	47

#### RELATED PRODUCTS



Acoustic cabinet



Compressor parallel connection kit

INDENT ITEM	
AC100ND	
Unit with no dryer	
Item Code	013184

Pre-filters for humid environments are available for compressors with dryers. For more information go to page 39.

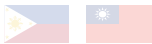

## DENTAL COMPRESSORS

### AC100Q Quiet Single Cylinder Oil-free Dental Compressor | 1 chair

The most compact of our high-performance dental compressor range, the AC100Q is designed to serve 1 chair. Our Q series of compressors significantly reduces noise levels, making them an excellent option when equipment is close to the surgery.

#### Details That Matter

- 3-year warranty
- Acoustic hood for significant noise reduction
- Certified food grade resin coated tank
- Added antimicrobial protection with Biocote® silver-ion lining in tank
- Unrivalled technical service back-up



3 YEAR WARRANTY



OIL FREE



HEPA H14 DRYER FILTER



LOW NOISE Q RANGE

#### AC100Q

Quiet Single Cylinder Oil-free Dental Compressor

Item Code 013145

#### SPECIFICATIONS

Power	60 HZ 0.7kW 4.9A 1PH 220V
Sound Output dB(A)	63
Max Air Flow at 5 Bar NL/min	67.5
Tank Size litres	30
Pressure Vessel	CE Certified

#### DIMENSIONS

Height mm	860
Width mm	660
Depth mm	600
Weight kg	57

#### INDENT ITEM

#### AC100QND

Unit with no dryer

Item Code 013162

#### RELATED PRODUCTS



Compressor parallel connection kit

Pre-filters for humid environments are available for compressors with dryers. For more information go to page 39.

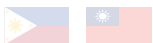

## DENTAL COMPRESSORS

### AC200 2 Cylinder Oil-free Dental Compressor | 2-3 chairs

One of the most popular models of our dental compressor range, the AC200 is designed to serve 2 to 3 chairs. Cattani compressors are oil-free and rigorously tested to deliver precision in hygienic air.

#### Details That Matter

- 3-year warranty
- Certified food grade resin coated tank
- Added antimicrobial protection with Biocote® silver-ion lining in tank
- Noise reduction option available (see AC200Q)
- Unrivalled technical service back-up



AC200	
2 Cylinder Oil-free Dental Compressor	
Item Code	013206
SPECIFICATIONS	
Power	60 HZ 1.5kW 9.2A 1PH 220V
Sound Output dB(A)	71
Max Air Flow at 5 Bar NI/min	160
Tank Size litres	30
Pressure Vessel	CE Certified
DIMENSIONS	
Height mm	720
Width mm	620
Depth mm	460
Weight kg	54

#### RELATED PRODUCTS



Acoustic cabinet



Compressor parallel connection kit

AC200ND	
Unit with no dryer	
Item Code	013284

**Pre-filters for humid environments are available for compressors with dryers. For more information go to page 39.**

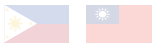

## DENTAL COMPRESSORS

### AC200Q Quiet 2 Cylinder Oil-free Dental Compressor | 2-3 chairs

The AC200Q is designed to serve 2 to 3 chairs. Our Q series of compressors significantly reduces noise levels, making them an excellent option when equipment is close to the surgery.

#### Details That Matter

- 3-year warranty
- Acoustic hood for significant noise reduction
- Certified food grade resin coated tank
- Added antimicrobial protection with Biocote® silver-ion lining in tank
- Unrivalled technical service back-up



3 YEAR WARRANTY



OIL FREE



HEPA H14 DRYER FILTER



LOW NOISE Q RANGE

#### AC200Q

Quiet 2 Cylinder Oil-free Dental Compressor

Item Code 013245

#### SPECIFICATIONS

Power 60 HZ 1.5kW 9.2A 1PH 220V

Sound Output dB(A) 63

Max Air Flow at 5 Bar NL/min 160

Tank Size litres 30

Pressure Vessel CE Certified

#### DIMENSIONS

Height mm 860

Width mm 660

Depth mm 600

Weight kg 64

#### INDENT ITEM AC200QND

Unit with no dryer

Item Code 013262

#### RELATED PRODUCTS



Compressor parallel connection kit

Pre-filters for humid environments are available for compressors with dryers. For more information go to page 39.

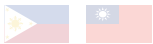

## DENTAL COMPRESSORS

### AC300 3 Cylinder Oil-free Dental Compressor | 3-4 chairs

One of our most popular models of the dental compressor range, the AC300 is designed to serve 3 to 4 chairs. Cattani compressors deliver high performance dry air and are completely oil-free.

#### Details That Matter

- 3-year warranty
- Certified food grade resin coated tank
- Added antimicrobial protection with Biocote® silver-ion lining in tank
- Noise reduction option available (see AC300Q)
- Unrivalled technical service back-up



AC300	
3 Cylinder Oil-free Dental Compressor	
Item Code	013306
SPECIFICATIONS	
Power	60 HZ 1.75kW 12.2A 1PH 220V
Sound Output dB(A)	73.6
Max Air Flow at 5 Bar NI/min	238
Tank Size litres	45
Pressure Vessel	CE Certified
DIMENSIONS	
Height mm	750
Width mm	620
Depth mm	520
Weight kg	65

INDENT ITEM	
AC300ND	
Unit with no dryer	
Item Code	013384

#### RELATED PRODUCTS



Acoustic cabinet



Compressor parallel connection kit

**Pre-filters for humid environments are available for compressors with dryers. For more information go to page 39.**



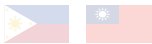

## DENTAL COMPRESSORS

### AC300Q Quiet 3 Cylinder Oil-free Dental Compressor | 3-4 chairs

One of our most popular models of the quiet dental compressor range, the AC300Q is designed to serve 3 to 4 chairs. Our Q series of compressors significantly reduces noise levels, making them an excellent option when equipment is close to the surgery.

#### Details That Matter

- 3-year warranty
- Acoustic hood for significant noise reduction
- Certified food grade resin coated tank
- Added antimicrobial protection with Biocote® silver-ion lining in tank
- Unrivalled technical service back-up



3 YEAR WARRANTY



OIL FREE



HEPA H14 DRYER FILTER



LOW NOISE Q RANGE

AC300Q	
Quiet 3 Cylinder Oil-free Dental Compressor	
Item Code	013345
SPECIFICATIONS	
Power	60 HZ 1.75kW 12.2A 1PH 220V
Sound Output dB(A)	68
Max Air Flow at 5 Bar NL/min	238
Tank Size litres	45
Pressure Vessel	CE Certified
DIMENSIONS	
Height mm	979
Width mm	720
Depth mm	700
Weight kg	80

#### RELATED PRODUCTS



Compressor parallel connection kit

INDENT ITEM	
AC300QND	
Unit with no dryer	
Item Code	013362

Pre-filters for humid environments are available for compressors with dryers. For more information go to page 39.

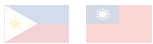

## DENTAL COMPRESSORS

### AC400-1P Tandem 2 Cylinder Oil-free Dental Compressor | 5-6 chairs

With a 100-litre tank, the AC400-1P is designed to serve 5 to 6 chairs, the ideal setup for a growing practice. This model is designed to deliver dry, oil-free, and hygienic air operating on single-phase power (three-phase also available).

#### Details That Matter

- 3-year warranty
- Certified food grade resin coated tank
- Added antimicrobial protection with Biocote® silver-ion lining in tank
- Noise reduction option available (see AC400Q-1P)
- Three-phase option available (See AC400)



AC400-1P	
Tandem 2 Cylinder Oil-free Dental Compressor	
Item Code	013408
SPECIFICATIONS	
Power	60 HZ 3kW 18.4A 1PH 220V
Sound Output dB(A)	73
Max Air Flow at 5 Bar NI/min	320
Tank Size litres	100
Pressure Vessel	CE Certified
DIMENSIONS	
Height mm	745
Width mm	1200
Depth mm	550
Weight kg	112

#### RELATED PRODUCTS



Compressor parallel connection kit

**Pre-filters for humid environments are available for compressors with dryers. For more information go to page 39.**

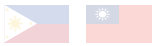

## DENTAL COMPRESSORS

### AC400Q Quiet Tandem 2 Cylinder Oil-free Dental Compressor | 5-6 chairs

With a 100-litre tank, the AC400Q is designed to serve 5 to 6 chairs, the ideal setup for a growing practice. This model is designed with noise reduction, operating on three-phase power (single-phase also available).

#### Details That Matter

- 3-year warranty
- Acoustic hood for significant noise reduction
- Certified food grade resin coated tank
- Added antimicrobial protection with Biocote® silver-ion lining in tank
- Single-phase option available (See AC400Q-1P)
- Unrivalled technical service back-up



AC400Q	
Quiet Tandem 2 Cylinder Oil-free Dental Compressor	
Item Code	Upon Request
<b>SPECIFICATIONS</b>	
Power	60 HZ 3kW 7.2A 3PH 380V
Sound Output dB(A)	63.8
Max Air Flow at 5 Bar NL/min	320
Tank Size litres	100
Pressure Vessel	CE Certified
<b>DIMENSIONS</b>	
Height mm	890
Width mm	1200
Depth mm	650
Weight kg	135

#### RELATED PRODUCTS



Ventilation fan kits



Three-phase compressor parallel connection kit

**Pre-filters for humid environments are available for compressors with dryers. For more information go to page 39.**

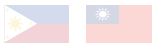

## DENTAL COMPRESSORS

### AC600 Tandem 3 Cylinder Oil-free Dental Compressor | 7-8 chairs

Designed to deliver dry, oil-free, and hygienic air at large facilities, the AC600 serves 7 to 8 chairs. With a 150-litre tank, this oil-free compressor has been rigorously tested to deliver world-class precision in dental air technology.

#### Details That Matter

- 3-year warranty
- 150-litre tank capacity
- Certified food grade resin coated tank
- Added antimicrobial protection with Biocote® silver-ion lining in tank
- Noise reduction option available (see AC600Q)
- Unrivalled technical service back-up



AC600	
Tandem 3 Cylinder Oil-free Dental Compressor	
Item Code	Upon Request
<b>SPECIFICATIONS</b>	
Power	60 HZ 3.5kW 9.4A 3PH 380V
Sound Output dB(A)	74
Max Air Flow at 5 Bar NI/min	476
Tank Size litres	150
Pressure Vessel	CE Certified
<b>DIMENSIONS</b>	
Height mm	890
Width mm	1320
Depth mm	590
Weight kg	124

#### RELATED PRODUCTS



Three-phase compressor parallel connection kit

**Pre-filters for humid environments are available for compressors with dryers. For more information go to page 39.**

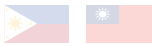

## DENTAL COMPRESSORS

### AC600Q Quiet Tandem 3 Cylinder Oil-free Dental Compressor | 7-8 chairs

Designed to deliver dry, oil-free, and hygienic air at large facilities, the AC600Q serves 7 to 8 chairs. This model significantly reduces noise levels, making it an excellent option when equipment is close to the surgery.

#### Details That Matter

- 3-year warranty
- 150-litre tank capacity
- Acoustic hood for significant noise reduction
- Certified food grade resin coated tank
- Added antimicrobial protection with Biocote® silver-ion lining in tank
- Unrivalled technical service back-up



AC600Q	
Quiet Tandem 3 Cylinder Oil-free Dental Compressor	
Item Code	Upon Request
SPECIFICATIONS	
Power	60 HZ 3.5kW 9.4A 3PH 380V
Sound Output dB(A)	70.4
Max Air Flow at 5 Bar NL/min	476
Tank Size litres	150
Pressure Vessel	CE Certified
DIMENSIONS	
Height mm	1040
Width mm	1320
Depth mm	770
Weight kg	169

#### RELATED PRODUCTS



Three-phase compressor parallel connection kit

**Pre-filters for humid environments are available for compressors with dryers. For more information go to page 39.**

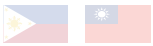

# LARGE PLANT COMPRESSOR

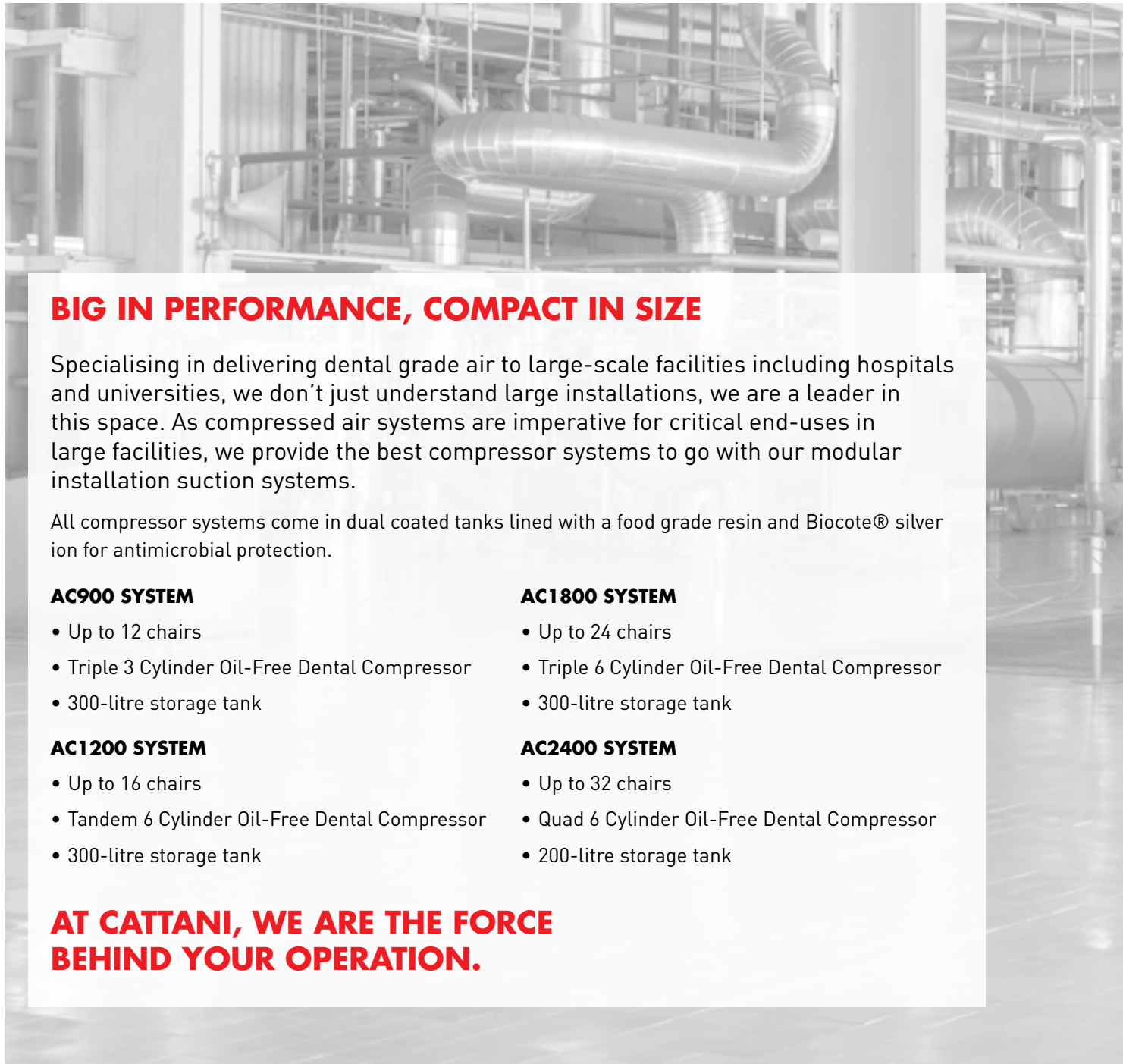

## BIG IN PERFORMANCE, COMPACT IN SIZE

Specialising in delivering dental grade air to large-scale facilities including hospitals and universities, we don't just understand large installations, we are a leader in this space. As compressed air systems are imperative for critical end-uses in large facilities, we provide the best compressor systems to go with our modular installation suction systems.

All compressor systems come in dual coated tanks lined with a food grade resin and Biocote® silver ion for antimicrobial protection.

### AC900 SYSTEM

- Up to 12 chairs
- Triple 3 Cylinder Oil-Free Dental Compressor
- 300-litre storage tank

### AC1200 SYSTEM

- Up to 16 chairs
- Tandem 6 Cylinder Oil-Free Dental Compressor
- 300-litre storage tank

### AC1800 SYSTEM

- Up to 24 chairs
- Triple 6 Cylinder Oil-Free Dental Compressor
- 300-litre storage tank

### AC2400 SYSTEM

- Up to 32 chairs
- Quad 6 Cylinder Oil-Free Dental Compressor
- 200-litre storage tank

**AT CATTANI, WE ARE THE FORCE BEHIND YOUR OPERATION.**



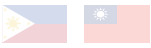



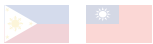

## DENTAL COMPRESSORS

### AC900 Triple 3 Cylinder Oil-free Dental Compressor | Up to 12 chairs

Designed to deliver dry, oil-free, and hygienic air at large facilities, the AC900 serves up to 12 chairs. With a 300-litre tank, this oil-free compressor has been rigorously tested and ready to deliver world-class performance in dental air technology.

#### Details That Matter

- 3-year warranty
- 300-litre tank capacity
- Certified food grade resin coated tank
- Added antimicrobial protection with Biocote® silver-ion lining in tank
- Unrivalled technical service back-up



AC900	
	Triple 3 Cylinder Oil-free Dental Compressor
Item Code	013597
SPECIFICATIONS	
Power	60 HZ 5.25kW 14.1A 3PH 380V
Sound Output dB(A)	75
Max Air Flow at 5 Bar NI/min	714
Tank Size litres	300
Pressure Vessel	CE Certified
DIMENSIONS	
Height mm	1000
Width mm	1800
Depth mm	810
Weight kg	260

#### RELATED PRODUCTS



Three-phase compressor parallel connection kit

**Pre-filters for humid environments are available for compressors with dryers. For more information go to page 39.**

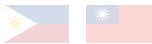

## DENTAL COMPRESSORS

### AC1200 Tandem 6 Cylinder Oil-free Dental Compressor | Up to 16 chairs

Designed to deliver dry, oil-free, and hygienic air at large facilities, the AC1200 serves up to 16 chairs. With a 300-litre tank, this high-performance unit has been rigorously tested to deliver continuous and reliable precision in air technology.

#### Details That Matter

- 3-year warranty
- 300-litre tank capacity
- Certified food grade resin coated tank
- Added antimicrobial protection with Biocote® silver-ion lining in tank
- Unrivalled technical service back-up



AC1200	
Tandem 6 Cylinder Oil-free Dental Compressor	
Item Code	013588
<b>SPECIFICATIONS</b>	
Power	60 HZ 7.6kW 18.5A 3PH 380V
Sound Output dB(A)	81
Max Air Flow at 5 Bar NL/min	952
Tank Size litres	300
Pressure Vessel	CE Certified
<b>DIMENSIONS</b>	
Height mm	1100
Width mm	1800
Depth mm	880
Weight kg	303

#### RELATED PRODUCTS



Three-phase compressor parallel connection kit

Pre-filters for humid environments are available for compressors with dryers. For more information go to page 39.

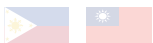

## DENTAL COMPRESSORS

### AC1800 Triple 6 Cylinder Oil-free Dental Compressor | Up to 24 chairs

Manufactured with patented low-friction components to prolong the lifespan of the unit, the AC1800 serves up to 24 chairs. With a 300-litre tank, this high-performance unit is ready to deliver world-class precision at large facilities.

#### Details That Matter

- 3-year warranty
- 300-litre tank capacity
- Certified food grade resin coated tank
- Added antimicrobial protection with Biocote® silver-ion lining in tank
- Unrivalled technical service back-up



	<b>AC1800</b>
	Triple 6 Cylinder Oil-free Dental Compressor
Item Code	013581
<b>SPECIFICATIONS</b>	
Power	60 HZ 11.4kW 27.8A 3PH 380V
Sound Output dB(A)	82.5
Max Air Flow at 5 Bar NI/min	1428
Tank Size litres	300
Pressure Vessel	CE Certified
<b>DIMENSIONS</b>	
Height mm	1100
Width mm	1800
Depth mm	1100
Weight kg	394

#### RELATED PRODUCTS



Three-phase compressor parallel connection kit

**Pre-filters for humid environments are available for compressors with dryers. For more information go to page 39.**

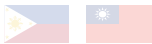

## DENTAL COMPRESSORS

### ACB400 Quad 6 Cylinder Oil-free Dental Compressor | Up to 32 chairs

The largest of our AC Cattani compressor range, the AC2400 serves up to 32 chairs. Manufactured with patented low-friction components for continuous and reliable operation, this high-performance unit is ready to deliver world-class precision at large facilities.

#### Details That Matter

- 3-year warranty
- 200-litre tank capacity
- Certified food grade resin coated tank
- Added antimicrobial protection with Biocote® silver-ion lining in tank
- Unrivalled technical service back-up



ACB400	
Quad 6 Cylinder Oil-free Dental Compressor	
Item Code	Upon Request
SPECIFICATIONS	
Power	60 HZ 15.2kW 37A 3PH 380V
Sound Output dB(A)	83.5
Max Air Flow at 5 Bar NL/min	1680
Tank Size litres	200
Pressure Vessel	CE Certified
DIMENSIONS	
Height mm	2000
Width mm	1550
Depth mm	760
Weight kg	300

#### RELATED PRODUCTS



Three-phase compressor parallel connection kit

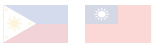

# CAD/CAM COMPRESSORS



3 YEAR WARRANTY



OIL FREE



LOW NOISE Q RANGE

## THE PURPOSE-BUILT ADVANTAGE

Making the correct choice for your plant equipment early on is crucial for your practice and/or dental laboratory in the long run. Cattani users know we specialise in unequalled precision and quality of purpose-built solutions. This is especially true when it comes to CAD/CAM milling.

Cattani CAD/CAM compressors are the purpose-built solution developed specifically to meet the demands set by CAD/CAM mill manufacturers.





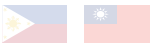

### **THE OPTIMAL PURPOSE-BUILT MILL PERFORMANCE**

Generalised solutions can be appealing in the short-term. In the case of dental grade air delivery, it is best to leave nothing to chance and have the right equipment fit for purpose. Cattani CAD/CAM compressors are built to maintain a constant and sustainable operating pressure of between 8 and 10 Bar, which is 2 Bar higher in pressure than the standard compressors.

### **IT'S NOT JUST EQUIPMENT, IT'S AN INVESTMENT**

We believe in our equipment so much that we offer a 3-year warranty.

### **DENTAL GRADE HYGIENE**

Cattani compressors produce quality dental grade air by removing 99.975% of particles down to 0.3 micron. Air is then preserved in a dual coated compressor tank lined with a food grade resin and Biocote® silver ion for antimicrobial protection. Cattani compressed air quality is supported by an ISO 8573-1 standard compliance with Class 1:4:2.

### **GUARANTEED CONTINUOUS AIRFLOW**

Cattani compressors guarantee a constant supply of air from the dual coated tank, even during system regeneration and cooling times. The intelligent technology is designed this way to ensure maximum performance while preserving the life of the unit.

### **NOISE REDUCTION OPTIONS AVAILABLE**

Where space is valuable and limited, noise can be an issue. For that, we offer noise reduction options for the (Q Series) CAD/CAM compressors.



**AT CATTANI, WE DON'T COMPROMISE. WE SPECIALISE.**

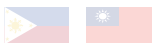

## AC310 3 Cylinder CAD/CAM Compressor

One of the most popular model in our CAD/CAM compressor range, the AC310 comes with a 45-litre tank capacity. Cattani compressors are completely oil-free, offered specifically to meet the demands set by CAD/CAM manufacturers.

### Details That Matter

- 3-year warranty
- Purpose-built to maintain an 8-bar pressure over long CAM cycles
- Certified food grade resin coated tank
- Added antimicrobial protection with Biocote® silver-ion lining in tank
- Noise reduction option available (see AC310Q)
- Pre-filter for humid climates available upon request



AC310	
	3 Cylinder CAD/CAM Compressor
Item Code	013322
<b>SPECIFICATIONS</b>	
Power	60 HZ 1.75kW 12.2A 1PH 220V
Sound Output dB(A)	73.6
<b>Continuous Airflow at 8 Bar NL/min</b>	<b>108</b>
Max Air Flow at 8 Bar NL/min	165
Tank Size litres	45
Pressure Vessel	CE Certified
<b>DIMENSIONS</b>	
Height mm	750
Width mm	620
Depth mm	520
Weight kg	64



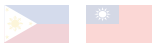

## AC310Q Quiet 3 Cylinder CAD/CAM Compressor

The AC310Q comes with a 45-litre tank capacity. AC310Q comes with a 45-litre tank capacity, and is ideal when noise is an issue, making them an excellent option when milling equipment is close to the surgery.

### Details That Matter

- 3-year warranty
- Acoustic hood for significant noise reduction
- Purpose-built to maintain an 8-bar pressure over long CAM cycles
- Certified food grade resin coated tank
- Added antimicrobial protection with Biocote® silver-ion lining in tank
- Pre-filter for humid climates available upon request



AC310Q	
Quiet 3 Cylinder CAD/CAM Compressor	
Item Code	013360
<b>SPECIFICATIONS</b>	
Power	60 HZ 1.75kW 12.2A 1PH 220V
Sound Output dB(A)	68
<b>Continuous Airflow at 8 Bar NL/min</b>	<b>108</b>
Max Air Flow at 8 Bar NL/min	165
Tank Size litres	45
Pressure Vessel	CE Certified
<b>DIMENSIONS</b>	
Height mm	979
Width mm	720
Depth mm	700
Weight kg	80

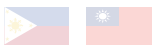

## AC410 Tandem 2 Cylinder CAD/CAM Compressor

Specifically built for CAD/CAM milling, the AC410 compressor comes with a 100-litre tank capacity. This model is designed to deliver dry, oil-free, and hygienic air operating on three-phase power (single-phase also available).

### Details That Matter

- 3-year warranty
- Purpose-built to maintain an 8-bar pressure over long CAM cycles
- Certified food grade resin coated tank
- Added antimicrobial protection with Biocote® silver-ion lining in tank
- Noise reduction option available (see AC410Q)
- Single-phase option available (see AC410-1P)
- Pre-filter for humid climates available upon request

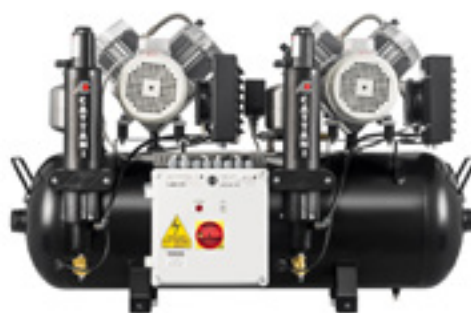

AC410	
Tandem 2 Cylinder CAD/CAM Compressor	
Item Code	013406
SPECIFICATIONS	
Power	60 HZ 3kW 7.2A 3PH 380V
Sound Output dB(A)	73
<b>Continuous Airflow at 8 Bar NL/min</b>	<b>140</b>
Max Air Flow at 8 Bar NL/min	215
Tank Size litres	100
Pressure Vessel	CE Certified
DIMENSIONS	
Height mm	745
Width mm	1155
Depth mm	550
Weight kg	112

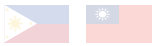

## AC410-1P Tandem 2 Cylinder CAD/CAM Compressor

Specifically built for CAD/CAM milling, the AC410-1P compressor comes with a 100-litre tank capacity. This model is designed to deliver dry, oil-free, and hygienic air operating on single-phase power (three-phase also available).

### Details That Matter

- 3-year warranty
- Purpose-built to maintain an 8-bar pressure over long CAM cycles
- Certified food grade resin coated tank
- Added antimicrobial protection with Biocote® silver-ion lining in tank.
- Noise reduction option available (see AC410Q-1P)
- Three-phase option available (see AC410)
- Pre-filter for humid climates available upon request



AC410-1P	
Tandem 2 Cylinder CAD/CAM Compressor	
Item Code	013411
<b>SPECIFICATIONS</b>	
Power	60 HZ 3kW 18.4A 1PH 220V
Sound Output dB(A)	73
<b>Continuous Airflow at 8 Bar NL/min</b>	<b>140</b>
Max Air Flow at 8 Bar NL/min	215
Tank Size litres	100
Pressure Vessel	CE Certified
<b>DIMENSIONS</b>	
Height mm	745
Width mm	1155
Depth mm	550
Weight kg	112



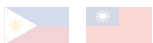

## AC410Q Quiet Tandem 2 Cylinder CAD/CAM Compressor

Specifically built for CAD/CAM milling, the AC410Q compressor comes with a 100-litre tank capacity. This model is designed for premium air delivery with noise reduction, operating on three-phase power (single-phase also available).

### Details That Matter

- 3-year warranty
- Purpose-built to maintain an 8-bar pressure over long CAM cycles
- Acoustic hood for significant noise reduction
- Certified food grade resin coated tank
- Added antimicrobial protection with Biocote® silver-ion lining in tank
- Single-phase option available (See AC410Q-1P)
- Pre-filter for humid climates available upon request



### AC410Q

Quiet Tandem 2 Cylinder  
CAD/CAM Compressor

Item Code Upon Request

#### SPECIFICATIONS

Power	60 HZ 3kW 7.2A 3PH 380V
Sound Output dB(A)	63.8
<b>Continuous Airflow at 8 Bar NL/min</b>	<b>140</b>
Max Air Flow at 8 Bar NL/min	215
Tank Size litres	100
Pressure Vessel	CE Certified

#### DIMENSIONS

Height mm	890
Width mm	1160
Depth mm	650
Weight kg	135

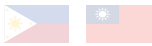

## CAD/CAM COMPRESSORS

### AC410Q-1P Quiet Tandem 2 Cylinder CAD/CAM Compressor

Specifically built for CAD/CAM milling, the AC410Q-1P compressor comes with a 100-litre tank capacity. This model is designed for premium air delivery with noise reduction, operating on single-phase power (three-phase also available).

#### Details That Matter

- 3-year warranty
- Purpose-built to maintain an 8-bar pressure over long CAM cycles
- Acoustic hood for significant noise reduction
- Certified food grade resin coated tank
- Added antimicrobial protection with Biocote® silver-ion lining in tank
- Three-phase option available (see AC410Q)
- Pre-filter for humid climates available upon request



3 YEAR WARRANTY



OIL FREE



HEPA H14 DRYER FILTER



LOW NOISE

#### AC410Q-1P

Quiet Tandem 2 Cylinder CAD/CAM Compressor

Item Code Upon Request

#### SPECIFICATIONS

Power	60 HZ 3kW 18.4A 1PH 220V
Sound Output dB(A)	63.8
<b>Continuous Airflow at 8 Bar NL/min</b>	<b>140</b>
Max Air Flow at 8 Bar NL/min	215
Tank Size litres	100
Pressure Vessel	CE Certified

#### DIMENSIONS

Height mm	890
Width mm	1160
Depth mm	650
Weight kg	135

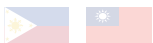

## AC610 Tandem 3 Cylinder CAD/CAM Compressor

The AC610 compressor is designed to deliver premium quality for higher performance requirements. With a 150-litre tank capacity, this oil-free compressor has been rigorously tested to deliver world-class precision for CAD/CAM milling.

### Details That Matter

- 3-year warranty
- Purpose-built to maintain an 8-bar pressure over long CAM cycles
- 150-litre tank capacity
- Certified food grade resin coated tank
- Added antimicrobial protection with Biocote® silver-ion lining in tank
- Noise reduction option available (see AC610Q)
- Pre-filter for humid climates available upon request



AC610	
Tandem 3 Cylinder CAD/CAM Compressor	
Item Code	Upon Request
<b>SPECIFICATIONS</b>	
Power	60 HZ 3.5kW 9.4A 3PH 380V
Sound Output dB(A)	74
<b>Continuous Airflow at 8 Bar NL/min</b>	<b>217</b>
Max Air Flow at 8 Bar NL/min	330
Tank Size litres	150
Pressure Vessel	CE Certified
<b>DIMENSIONS</b>	
Height mm	890
Width mm	1320
Depth mm	590
Weight kg	137

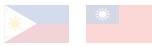

## CAD/CAM COMPRESSORS

### AC610Q Quiet Tandem 3 Cylinder CAD/CAM Compressor

The AC610Q compressor comes with a 150-litre tank capacity for higher performance requirements. Our Q series of compressors significantly reduces noise levels, making them an excellent option when CAD/CAM equipment is close to the surgery.

#### Details That Matter

- 3-year warranty
- Purpose-built to maintain an 8-bar pressure over long CAM cycles
- Acoustic hood for significant noise reduction
- 150-litre tank capacity
- Certified food grade resin coated tank
- Added antimicrobial protection with Biocote® silver-ion lining in tank
- Pre-filter for humid climates available upon request



AC610Q	
Quiet Tandem 3 Cylinder CAD/CAM Compressor	
Item Code	Upon Request
SPECIFICATIONS	
Power	60 HZ 3.5kW 9.4A 3PH 380V
Sound Output dB(A)	70.4
<b>Continuous Airflow at 8 Bar NL/min</b>	<b>217</b>
Max Air Flow at 8 Bar NL/min	330
Tank Size litres	150
Pressure Vessel	CE Certified
DIMENSIONS	
Height mm	1040
Width mm	1320
Depth mm	770
Weight kg	169



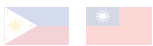

## AC910 Triple 3 Cylinder CAD/CAM Compressor

Our largest of the CAD/CAM compressor range, the AC910 comes with a 300-litre tank capacity. All our compressors are oil-free and have been rigorously tested to deliver world class performance in dental air technology.

### Details That Matter

- 3-year warranty
- Purpose-built to maintain an 8-bar pressure over long CAM cycles
- 300-litre tank capacity
- Certified food grade resin coated tank
- Added antimicrobial protection with Biocote® silver-ion lining in tank.
- Pre-filter for humid climates available upon request



AC910	
Triple 3 Cylinder CAD/CAM Compressor	
Item Code	Upon Request
<b>SPECIFICATIONS</b>	
Power	60 HZ 5.25kW 14.1A 3PH 380V
Sound Output dB(A)	75
<b>Continuous Airflow at 8 Bar NL/min</b>	<b>326</b>
Max Air Flow at 8 Bar NL/min	495
Tank Size litres	300
Pressure Vessel	CE Certified
<b>DIMENSIONS</b>	
Height mm	1000
Width mm	1800
Depth mm	810
Weight kg	260

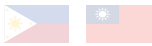

# COMPRESSOR ACCESSORIES

## Acoustic Cabinet for AC100, AC200 and AC300

The Cattani acoustic cabinet is a complete weatherproof, temperature controlled and acoustic solution. Designed for both outdoors or indoors installation. The cabinet is made using electro-galvanised metal plate and epoxy-polyester powders that can withstand rain and direct sunlight in hot and cold climates. The cabinet includes an inbuilt fan to effectively ventilate the compressor.

Reduces noise of the compressor to:

AC100 - 50 dB(A)

AC200 - 51 dB(A)

AC300 - 51 dB(A)



Order Number	Description
010800	Acoustic Cabinet 870mm W x 887mm H x 700mm D (84kg)

## HEPA H14 Filter for Compressor Drying Column

Order Number	Pack Qty
168429	1



## Air Inlet Filter for Compressor Head Unit

Order Number	Pack Qty
168563	1



## Dryer Pre Filter (for Humid Climates) Kit for Compressor

Fitted between the condenser and the desiccant dryer, and removes a percentage of condensation from the air before reaching the dryer. Can be easily retrofitted to existing compressors. (1 filter required per desiccant dryer, therefore 2 filters required for AC400 and AC600 etc).

Order Number	Pack Qty
K-E10000	1



## Auxiliary Control Panel

Allows for up to 4x of the same type 3PH compressors to be installed in parallel.

Order Number	Model Suited
070904	All 3 Phase Models

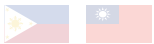

## COMPRESSOR SPARE PARTS

### Parts For Compressor Head Units (Pumps)

Order Number	Model Suited	Description
010862	All Models	Repair Kit for Head (Valve Plate and Gasket)
178601	All Models	Cylinder for Compressor
179802	All Models	Cylinder Head for Compressor
209920	All Models	Plastic Cooling Fan (Piston End of Head)
219600	All Models	Cap for Filter
168120	AC 100/200	Cover For Cooling Fan (Electrical Motor End)
178802	AC 300	Housing - 3 Cylinder Compressor
258853	AC 100/200	Motor Mount - 1 & 2 Cylinder Compressor
250021	AC 300/500/600	Motor Mount - 3 Cylinder Compressor
168619	AC 100	Compressor Head - Single Cylinder 1 Phase
168659	AC 200	Compressor Head - 2 Cylinder 1 Phase
168628	AC 400	Compressor Head - 2 Cylinder 3 Phase
168669	AC 300	Compressor Head - 3 Cylinder 1 Phase
168648	AC 500/600	Compressor Head - 3 Cylinder 3 Phase
169073	AC 1200/1800	Compressor Head - 6 Cylinder 3 Phase
169925	AC 100/200	Cooling Fan for Compressor (Electrical Motor End)
178805	AC100/200	Housing - 1 & 2 Cylinder Compressor
207506	AC 100/200	Plastic Cover (Black) for Cooling Fan (Crank End)

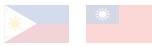

## COMPRESSOR SPARE PARTS

### Parts For Compressor

Order Number	Model Suited	Description
189320	All Models	Solenoid for Desiccant Dryer
189994	AC 100/200	Electrical Fan for Radiator – 1 & 2 Cylinder
189990	AC 300	Electrical Fan for Radiator – 3 Cylinder
199717	AC 100	Regenerating Tank for 1 Cylinder Compressors
199716	AC 200	Regenerating Tank for 2 Cylinder Compressors
199715	AC 300	Regenerating Tank for 3 Cylinder Compressors
169046	AC 100/200	Radiator for 2 Cylinder Compressors
169121	AC 300	Radiator for 3 Cylinder Compressors
189909	All Models	Pressure Switch for Compressor
169362	All Models	Condensate Drain Bottle Connection Assembly
209625	All Models	Drain Bottle for Compressor Condensate
169831	All Models	Non Return Valve for Compressor Tank

### Capacitors

Order Number	Description
189115	20 $\mu$ F Capacitor C87.0 "UL" Metal with 150mm Cable
189116	40 $\mu$ F Capacitor C87.0 "UL" Metal with 350mm Cable
189148	55 $\mu$ F Capacitor C87.0 "UL" Metal with 150mm Cable



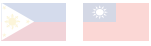

# SMART SUCTION



1 YEAR WARRANTY



INVERTER CONTROL



AMALGAM RETENTION



LOW NOISE Q RANGE

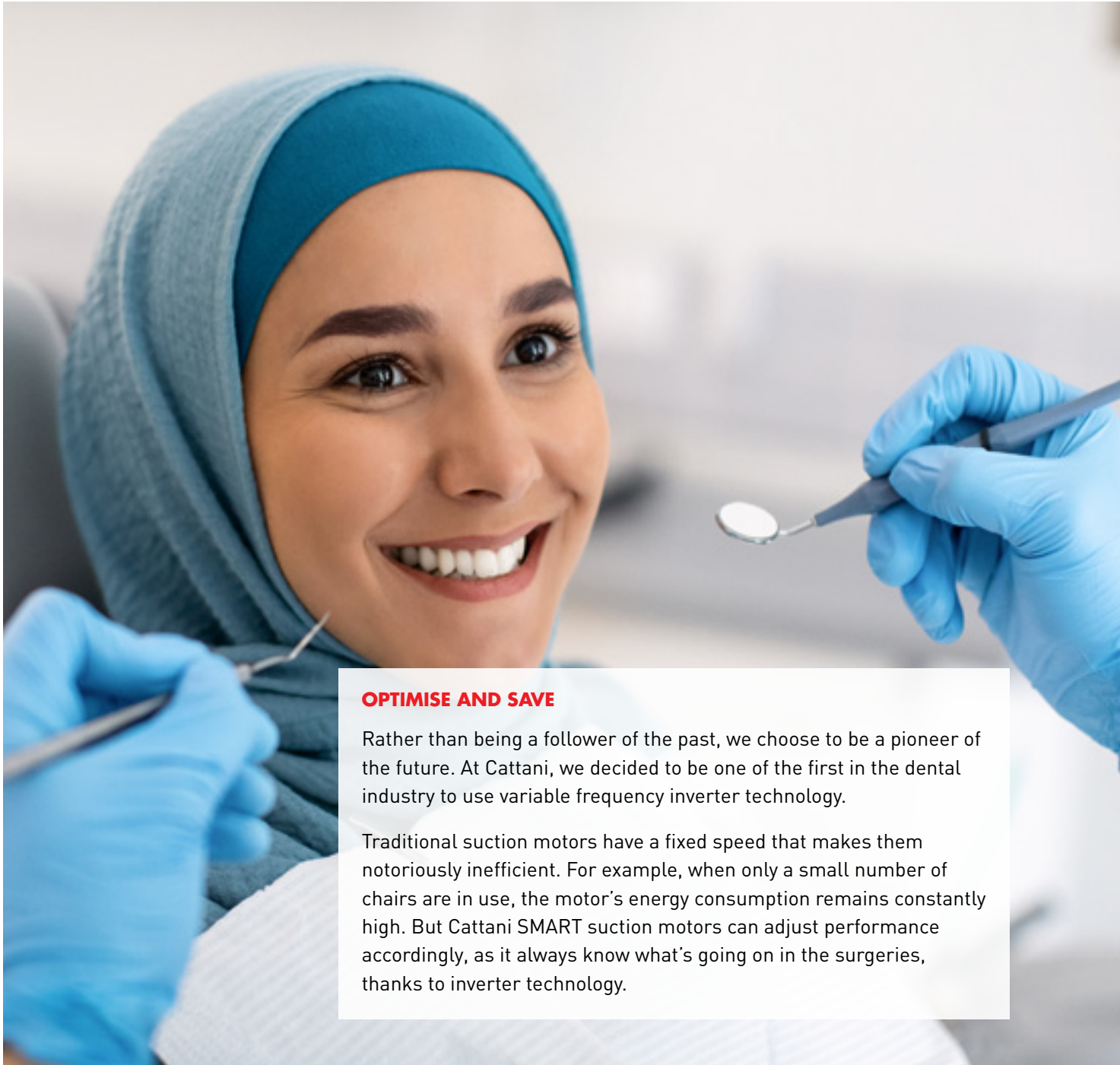

## OPTIMISE AND SAVE

Rather than being a follower of the past, we choose to be a pioneer of the future. At Cattani, we decided to be one of the first in the dental industry to use variable frequency inverter technology.

Traditional suction motors have a fixed speed that makes them notoriously inefficient. For example, when only a small number of chairs are in use, the motor's energy consumption remains constantly high. But Cattani SMART suction motors can adjust performance accordingly, as it always know what's going on in the surgeries, thanks to inverter technology.

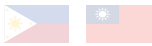

### SMART AND ECONOMICAL

Pioneered by Cattani, the inverter control intelligence is designed to optimise performance suction, while reducing energy costs. From the number of chairs in use, down to size of suction tip, the inverter control senses the real-time requirements of your practice, to adjust the unit speed and output accordingly. No more, no less.

### SMART SELF-PROTECTION MODE

In the event of a functional anomaly that could damage the machine, such as overload of fluids, excessive temperatures or even power surge, the SMART suction unit automatically switches to self-protection mode to overcome the issue, returning to normal operation once the situation is stabilised.

### NOISE REDUCTION BY HALF

The SMART Cube suction range is a perfect example of what can be achieved by Cattani innovation. The Cube's acoustic housing has the ability to cut perceived noise by half, not to mention the lower running costs through its clever design and inverter technology.

### PLUG AND PLAY POSSIBILITIES

As a market leader in modular installations, our "plug and play" parallel installation allows SMART suction systems to communicate with each other to deliver precise performance for your practice. From the single chair up to a hospital and university set-up, we have configurations to suit all needs, while ensuring built-in redundancy to ensure continuous operation.

### AMALGAM RETENTION

As a world leader in amalgam separation, Cattani's Hydrocyclone technology is at the forefront of amalgam retention technology. The Hydrocyclone has a retention rate of more than 98%, with no extra power consumption or noise, and can be easily retrofitted by a technician.



Turbo SMART Cube

Turbo SMART

**AT CATTANI, WE DON'T COMPROMISE. WE OPTIMISE.**

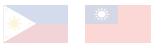

# SMART CUBE: HALF AS LOUD



## PEACE AND QUIET, PEACE OF MIND

All plant room equipment generates fluctuating noise which is inevitable at any dental practice. This led Cattani engineers to develop an innovative solution that not only reduces noise, but also with lower operating costs. Cattani's SMART Cube suction range is the prime example of what can be achieved with noise reduction and other efficiencies.

## THE SCIENCE WITHIN THE HOUSING

Cattani's engineers have been able to cut perceived noise by 50% with the Cube's acoustic housing. The Cube's compact design is just as powerful as its SMART counterparts, but uses a smaller motor, translating into lower running costs. With inverter technology as part of the package, energy savings are a given with SMART Cube.

## ENVIRONMENTAL SUSTAINABILITY

The introduction of our SMART suction systems in 2015 has shown a significant reduction in raw materials used compared to our Classic suction range. The vast improvement from this evolution has been evident in our Turbo SMART Cube system, where 13 kg (59%) of raw materials have been spared in each unit.

- Acoustic housing cuts perceived noise by 50%
- Inverter control slashes energy consumption
- Active self-protection mode during emergencies
- Sustainable production

## SMART SELF-PROTECTION MODE

In the event of a functional anomaly that could damage the machine, such as overload of fluids, excessive temperatures or even power surge, the SMART suction unit automatically switches to self-protection mode to overcome the issue, returning to normal operation once the situation is stabilised.

**SMART CUBE PROMISES NOT ONLY PEACE AND QUIET, BUT ALSO PEACE OF MIND.**

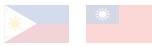

# INVERTER TECHNOLOGY

## THE TRUE MEANING OF PEAK PRECISION PERFORMANCE

Traditionally, conventional motor systems can lose over half their input energy before delivering end-use service. Therefore, whilst performance of the individual motor may be high, the efficiency of the whole system could improve substantially. This is where Cattani's inverter technology helps overcome this energy efficiency problem.

Cattani pioneered the use of inverter technology in dental suction equipment, which use a variable frequency drive (VFD) or variable speed drive (VSD) to control the speed of the motor for the purpose of energy saving and precision in performance control.

## BENEFITS OF INVERTER CONTROL:

- Power saving efficiency
- Independent variable speed control and speed transition control of the centrifugal separator and suction motor
- System management from multiple inputs (voltage monitoring, current monitoring, temperature monitoring for machine self-protection and fluid flow management).

## ULTIMATE CONTROL

The inverter technology controls the rotational speed of the motor by controlling its frequency and voltage supply. As the performance demand changes, the inverter control can simply increase or decrease the motor speed to meet the suction requirement. Each motor, (centrifuge and suction) are intelligently controlled by an independent inverter module. The result is constant, consistent, and reliable suction for a great patient and user experience.

## WHY SMART MATTERS

SMART suction inverter technology uses sensors to measure this demand for suction and adjusts the motor's speed to deliver precision performance. From the number of chairs in use, right down to size of suction tip and volume of fluids being aspirated, the inverter control identifies real-time requirements of your practice, monitoring its performance, as well as detecting and reporting abnormalities.

## PLUG AND PLAY, FOR CONTINUOUS OPERATION

Thanks to inverter technology, Cattani leads the way in modular installation of parallel units. Our "plug and play" parallel installation allows SMART suction systems to communicate with each other to deliver peak precision performance for your facility. From the single chair up to a hospital and university set-up, we have configurations to suit all needs, while ensuring built-in redundancy to ensure continuous operation.

**AT CATTANI, WE HAVE MASTERED PRECISION.**





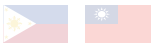

# AMALGAM RETENTION: THE CATTANI HYDROCYCLONE

Cattani is passionate about protecting the environment for future generations and has been at the forefront of addressing amalgam retention and separation.

The Hydrocyclone is a clever and effective concept that uses the fluid pressure created by the suction system to separate and retain amalgam, all without the need for moving parts. Fluids enter the Hydrocyclone cone and are forced downward in a spiral motion.

When the fluids hit the base of the Hydrocyclone they are forced to make a rapid inversion, while the heavier amalgam particles fall into a collection canister. If fluid velocity is not sufficient to achieve maximum retention, the system is intelligent enough to force the fluids back into the machine to recirculate until retention is achieved.

The retention rate of 98% or more exceeds with ISO 11143.

## **NO ADDITIONAL POWER CONSUMPTION, NO NOISE, NO EXTRA SPACE**

The beauty of the Hydrocyclone unit is that it uses no additional power at all, creates no noise, and operates within the same footprint of the SMART suction system. This is a revolutionary step towards a more sustainable world.

## **EASY INSTALLATION WITH RETROFIT OPTION**

Cattani SMART suction units can easily be retrofitted with Hydrocyclone units at any stage. As the Hydrocyclone fits within the same footprint of the existing SMART suction system no additional space requirements are needed.

The process is carried out on-site by a trained technician and takes less than an hour, to ensure minimal disruption to operation.

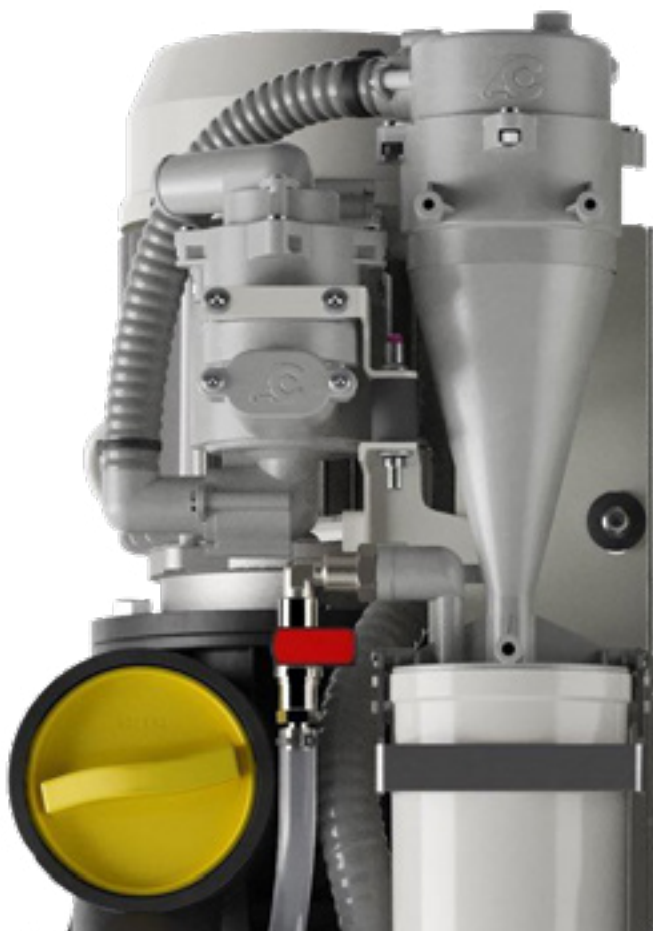

- Exceeds ISO 11143 Amalgam retention standard
- Fits within footprint of suction system
- No additional power required
- No additional noise

**AT CATTANI, WE ARE ABOUT SUSTAINABILITY.**

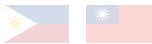

# SMART SUCTION

## Micro SMART with Keypad | 1-2 chairs

The most compact of our high-performance SMART suction range, the Micro SMART with Keypad is designed to serve 1 to 2 chairs. Developed with inverter control to provide consistent, high-performance suction while reducing energy costs.

### Details That Matter

- 1-year warranty
- Inverter control for performance and energy efficiency
- SMART self-protection in case of functional anomalies
- Modular installation capabilities
- Noise reduction option available (see SMART Cube)
- Amalgam retention option available



Micro SMART with Keypad	
Item Code	035050 + 181642
<b>SPECIFICATIONS</b>	
Power	60 HZ 1.12kW 8A 1PH 230V
Sound Output dB(A)	64
Max Air Flow at l/min	900
Max Vacuum for Continuous Operation mBar	210
Hydrocyclone Amalgam Retention	No
<b>DIMENSIONS</b>	
Height mm	600
Width mm	380
Depth mm	350
Weight kg	33

### RELATED PRODUCTS



PULI-JET Gentle 2.0  
Non-foaming  
Disinfectant



Pulse Cleaner

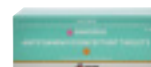

Antifoaming  
Disinfectant Tablets

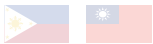

## SMART SUCTION

### Micro SMART with ISO 6 Hydrocyclone | 1-2 chairs

The most compact of our high-performance SMART suction range, the Micro SMART is designed to serve 1 to 2 chairs. Integrated with ISO 6 Hydrocyclone amalgam retention.

#### Details That Matter

- 1-year warranty
- ISO 6 Hydrocyclone amalgam retention
- Inverter control for performance and energy efficiency
- SMART self-protection in case of functional anomalies
- Modular installation capabilities
- Noise reduction option available (see SMART Cube)



1 YEAR WARRANTY



INVERTER CONTROL



AMALGAM RETENTION

#### Micro SMART with ISO 6 Hydrocyclone

Item Code 035060

#### SPECIFICATIONS

Power	60 HZ 1.12kW 8A 1PH 230V
Sound Output dB(A)	64
Max Air Flow at l/min	900
Max Vacuum for Continuous Operation mBar	210
Hydrocyclone Amalgam Retention	Yes

#### DIMENSIONS

Height mm	600
Width mm	380
Depth mm	350
Weight kg	33

#### RELATED PRODUCTS



PULI-JET Gentle 2.0  
Non-foaming  
Disinfectant



Pulse Cleaner



Antifoaming  
Disinfectant Tablets

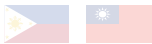

# SMART SUCTION

## Micro SMART Cube | 1-2 chairs

The most compact of our high-performance SMART suction Cube range, the Micro SMART Cube is designed to serve 1 to 2 chairs. The Cube's acoustic housing cuts perceived noise by 50%.

### Details That Matter

- 1-year warranty
- Acoustic housing reducing perceived noise by 50%
- Inverter control for performance and energy efficiency
- SMART self-protection in case of functional anomalies
- Modular installation capabilities
- Amalgam retention option available



Micro SMART Cube	
Item Code	035031 + 181644
<b>SPECIFICATIONS</b>	
Power	60 HZ 0.95kW 5.8A 1PH 230V
Sound Output dB(A)	59
Max Air Flow at l/min	1000
Max Vacuum for Continuous Operation mBar	210
Hydrocyclone Amalgam Retention	No
<b>DIMENSIONS</b>	
Height mm	470
Width mm	420
Depth mm	350
Weight kg	31

### RELATED PRODUCTS



PULI-JET Gentle 2.0  
Non-foaming  
Disinfectant



Pulse Cleaner



Antifoaming  
Disinfectant Tablets



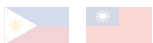

## SMART SUCTION

### Micro SMART Cube with ISO 6 Hydrocyclone | 1-2 chairs

The most compact of our high-performance SMART suction Cube range, the Micro SMART is designed to serve 1 to 2 chairs. Integrated with amalgam retention, the Cube's acoustic housing cuts perceived noise by 50%.

#### Details That Matter

- 1-year warranty
- Acoustic housing reducing perceived noise by 50%
- ISO 6 Hydrocyclone amalgam retention
- Inverter control for performance and energy efficiency
- SMART self-protection in case of functional anomalies
- Modular installation capabilities



#### Micro SMART Cube with ISO 6 Hydrocyclone

Item Code 035030

#### SPECIFICATIONS

Power	60 HZ 0.95kW 5.8A 1PH 230V
Sound Output dB(A)	59
Max Air Flow at l/min	1000
Max Vacuum for Continuous Operation mBar	210
Hydrocyclone Amalgam Retention	Yes

#### DIMENSIONS

Height mm	470
Width mm	420
Depth mm	350
Weight kg	31

#### RELATED PRODUCTS



PULI-JET Gentle 2.0  
Non-foaming  
Disinfectant



Pulse Cleaner



Antifoaming  
Disinfectant Tablets

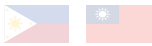

# SMART SUCTION

## Turbo SMART A | 2-3 chairs

Designed with Cattani pioneered inverter technology, the Turbo SMART A delivers consistent, high-performance suction to 2 to 3 chairs. Capable of upgrading to Turbo SMART B to serve 4 chairs, without the need for additional space.

### Details That Matter

- 1-year warranty
- Capability to upgrade to a 4-chair capacity
- Inverter control for performance and energy efficiency
- SMART self-protection in case of functional anomalies
- Modular installation capabilities
- Amalgam retention option available
- Noise reduction option available (see SMART Cube)



Turbo SMART A	
Item Code	035105
<b>SPECIFICATIONS</b>	
Power	60 HZ 1.5kW 6.5A 1PH 230V
Sound Output dB(A)	69
Max Air Flow at l/min	1400
Max Vacuum for Continuous Operation mBar	210
Hydrocyclone Amalgam Retention	No
<b>DIMENSIONS</b>	
Height mm	645
Width mm	400
Depth mm	330
Weight kg	49

### RELATED PRODUCTS



PULI-JET Gentle 2.0  
Non-foaming  
Disinfectant



Pulse Cleaner



Antifoaming  
Disinfectant Tablets

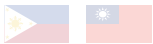

## SMART SUCTION

### Turbo SMART A with ISO 18 Hydrocyclone | 2-3 chairs

Designed with inverter technology, the Turbo SMART A delivers consistent, high-performance suction to 2 to 3 chairs. Integrated with amalgam retention, with the capability of upgrading to Turbo SMART B to serve 4 chairs.

#### Details That Matter

- 1-year warranty
- Capability to upgrade to a 4-chair capacity
- ISO 18 Hydrocyclone amalgam retention
- Inverter control for performance and energy efficiency
- SMART self-protection in case of functional anomalies
- Modular installation capabilities.
- Noise reduction option available (see SMART Cube)



1 YEAR WARRANTY



INVERTER CONTROL



AMALGAM RETENTION

#### Turbo SMART A with ISO 18 Hydrocyclone

Item Code 035115

##### SPECIFICATIONS

Power	60 HZ 1.5kW 6.5A 1PH 230V
Sound Output dB(A)	69
Max Air Flow at l/min	1400
Max Vacuum for Continuous Operation mBar	210
Hydrocyclone Amalgam Retention	Yes

##### DIMENSIONS

Height mm	645
Width mm	400
Depth mm	330
Weight kg	50

#### RELATED PRODUCTS



PULI-JET Gentle 2.0  
Non-foaming  
Disinfectant



Pulse Cleaner



Antifoaming  
Disinfectant Tablets

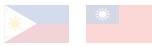

# SMART SUCTION

## Turbo SMART A Cube | 2-3 chairs

Designed with inverter technology, the Turbo SMART A delivers consistent, high-performance suction to 2 to 3 chairs. Comes with noise reduction acoustic housing, with the capability of upgrading to Turbo SMART B to serve 4 chairs.

### Details That Matter

- 1-year warranty
- Acoustic housing reducing perceived noise by 50%
- Capability to upgrade to a 4-chair capacity
- Inverter control for performance and energy efficiency
- SMART self-protection in case of functional anomalies
- Modular installation capabilities
- Amalgam retention option available



Turbo SMART A Cube	
Item Code	035121
<b>SPECIFICATIONS</b>	
Power	60 HZ 1.1kW 6.8A 1PH 230V
Sound Output dB(A)	60
Max Air Flow at l/min	1400
Max Vacuum for Continuous Operation mBar	200
Hydrocyclone Amalgam Retention	No
<b>DIMENSIONS</b>	
Height mm	650
Width mm	500
Depth mm	370
Weight kg	43

### RELATED PRODUCTS



PULI-JET Gentle 2.0  
Non-foaming  
Disinfectant



Pulse Cleaner



Antifoaming  
Disinfectant Tablets



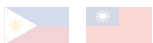

## SMART SUCTION

### Turbo SMART A Cube with ISO 18 Hydrocyclone | 2-3 chairs

Designed with inverter technology, the Turbo SMART A delivers consistent, high-performance suction to 2 to 3 chairs. Integrated with Hydrocyclone amalgam retention, with the capability of upgrading to Turbo SMART B to serve 4 chairs.

#### Details That Matter

- 1-year warranty
- Acoustic housing reducing perceived noise by 50%
- ISO 18 Hydrocyclone amalgam retention
- Capability to upgrade to a 4-chair capacity
- Inverter control for performance and energy efficiency
- SMART self-protection in case of functional anomalies



#### Turbo SMART A Cube with ISO 18 Hydrocyclone

Item Code 035120

#### SPECIFICATIONS

Power	60 HZ 1.1kW 6.8A 1PH 230V
Sound Output dB(A)	60
Max Air Flow at l/min	1400
Max Vacuum for Continuous Operation mBar	200
Hydrocyclone Amalgam Retention	Yes

#### DIMENSIONS

Height mm	650
Width mm	500
Depth mm	370
Weight kg	44

#### RELATED PRODUCTS



PULI-JET Gentle 2.0  
Non-foaming  
Disinfectant



Pulse Cleaner



Antifoaming  
Disinfectant Tablets

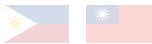

# SMART SUCTION

## Turbo SMART B | Up to 4 chairs

Designed with Cattani pioneered inverter technology, the Turbo SMART B adjusts performance according to suction demands, improving energy efficiency. This model delivers consistent, high-performance suction to 4 chairs.

### Details That Matter

- 1-year warranty
- Inverter technology for performance control and energy efficiency
- SMART self-protection in case of functional anomalies
- Modular installation capabilities
- Amalgam retention option available
- Noise reduction option available (see SMART Cube)



Turbo SMART B	
Item Code	035105 + 035500
<b>SPECIFICATIONS</b>	
Power	60 HZ 1.8kW 7.5A 1PH 230V
Sound Output dB(A)	73.7
Max Air Flow at l/min	1750
Max Vacuum for Continuous Operation mBar	210
Hydrocyclone Amalgam Retention	No
<b>DIMENSIONS</b>	
Height mm	645
Width mm	400
Depth mm	330
Weight kg	50

### RELATED PRODUCTS



PULI-JET Gentle 2.0  
Non-foaming  
Disinfectant



Pulse Cleaner



Antifoaming  
Disinfectant Tablets

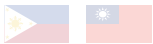

## SMART SUCTION

### Turbo SMART B with ISO 18 Hydrocyclone | Up to 4 chairs

Designed with Cattani pioneered inverter technology, the Turbo SMART B delivers consistent, high-performance suction to 4 chairs. Integrated with ISO 18 Hydrocyclone amalgam retention.

#### Details That Matter

- 1-year warranty
- Inverter control for performance and energy efficiency
- ISO 18 Hydrocyclone amalgam retention
- SMART self-protection in case of functional anomalies
- Modular installation capabilities
- Noise reduction option available (see SMART Cube)



1 YEAR WARRANTY



INVERTER CONTROL



AMALGAM RETENTION

#### Turbo SMART B with ISO 18 Hydrocyclone

Item Code 035115 + 035500

##### SPECIFICATIONS

Power	60 HZ 1.8kW 7.5A 1PH 230V
Sound Output dB(A)	73.7
Max Air Flow at l/min	1750
Max Vacuum for Continuous Operation mBar	210
Hydrocyclone Amalgam Retention	Yes

##### DIMENSIONS

Height mm	645
Width mm	400
Depth mm	330
Weight kg	50

#### RELATED PRODUCTS



PULI-JET Gentle 2.0  
Non-foaming  
Disinfectant



Pulse Cleaner



Antifoaming  
Disinfectant Tablets

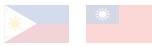

# SMART SUCTION

## Turbo SMART B Cube | Up to 4 chairs

Designed with Cattani-pioneered inverter technology, the Turbo SMART B adjusts performance according to suction demands, improving energy efficiency. Comes with noise reduction acoustic housing, delivering high-performance suction to 4 chairs.

### Details That Matter

- 1-year warranty
- Acoustic housing reducing perceived noise by 50%
- Inverter technology for performance control and energy efficiency
- SMART self-protection in case of functional anomalies
- Modular installation capabilities
- Amalgam retention option available



Turbo SMART B Cube	
Item Code	035121 + 035500
<b>SPECIFICATIONS</b>	
Power	60 HZ 1.5kW 8.7A 1PH 230V
Sound Output dB(A)	60
Max Air Flow at l/min	1700
Max Vacuum for Continuous Operation mBar	200
Hydrocyclone Amalgam Retention	No
<b>DIMENSIONS</b>	
Height mm	650
Width mm	500
Depth mm	370
Weight kg	44

### RELATED PRODUCTS



PULI-JET Gentle 2.0  
Non-foaming  
Disinfectant



Pulse Cleaner



Antifoaming  
Disinfectant Tablets

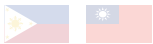

## SMART SUCTION

### Turbo SMART B Cube with ISO 18 Hydrocyclone | Up to 4 chairs

Designed with Cattani-pioneered inverter technology, the Turbo SMART B delivers consistent, high-performance suction to 4 chairs. Comes with noise reduction acoustic housing and integrated with ISO 18 Hydrocyclone amalgam retention.

#### Details That Matter

- 1-year warranty
- ISO 18 Hydrocyclone amalgam retention
- Acoustic housing reducing perceived noise by 50%
- Inverter control for performance and energy efficiency
- SMART self-protection in case of functional anomalies
- Modular installation capabilities



#### Turbo SMART B Cube with ISO 18 Hydrocyclone

Item Code 035120 + 035500

##### SPECIFICATIONS

Power	60 HZ 1.5kW 8.7A 1PH 230V
Sound Output dB(A)	60
Max Air Flow at l/min	1700
Max Vacuum for Continuous Operation mBar	200
Hydrocyclone Amalgam Retention	Yes

##### DIMENSIONS

Height mm	650
Width mm	500
Depth mm	370
Weight kg	44

#### RELATED PRODUCTS



PULI-JET Gentle 2.0  
Non-foaming  
Disinfectant



Pulse Cleaner



Antifoaming  
Disinfectant Tablets



# WORKING AS ONE

## MAGNOLIA BY CATTANI



Magnolia products are designed specifically for cleaning, disinfecting and sanitising dental suction systems and surgeries. Magnolia can be trusted to keep your practice hygienic.

- PULI-JET Gentle 2.0 – ideal solution for daily suction system disinfection (Malaysia only)
- Pulse Cleaner – PULI-JET Gentle 2.0's agitating partner in grime
- Antifoaming Disinfectant Tablets – keep blood/mucus foam at bay
- Lubri-Jet – silicone lubricant for suction unit o-rings

Please go to page 120 to learn more about our Magnolia range.

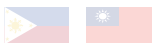

## Turbo SMART 2V | Up to 4 chairs

With two fans operating in series, the Turbo SMART 2V provides the additional vacuum pressure when required. Ideal for dental surgeries that have challenging pipework. Using Cattani pioneered inverter technology, the Turbo SMART 2V is designed to serve 4 chairs.

### Details That Matter

- 1-year warranty
- Inverter control for performance and energy efficiency
- SMART self-protection in case of functional anomalies
- Amalgam retention option available



Model with ISO 18 Hydrocyclone pictured.



Turbo SMART 2V	
Item Code	035130
<b>SPECIFICATIONS</b>	
Power	60 HZ 1.5kW 9A 1PH 230V
Sound Output dB(A)	70
Max Air Flow at l/min	1600
Max Vacuum for Continuous Operation mBar	280
<b>DIMENSIONS</b>	
Height mm	650
Width mm	540
Depth mm	400
Weight kg	41

### RELATED PRODUCTS



PULI-JET Gentle 2.0  
Non-foaming  
Disinfectant



Pulse Cleaner

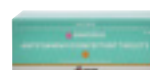

Antifoaming  
Disinfectant Tablets



## SMART SUCTION

### Turbo SMART 2V with ISO 18 Hydrocyclone | Up to 4 chairs

With two fans operating in series, this unit provides the additional vacuum pressure when required. Ideal for dental surgeries that have challenging pipework. Integrated with amalgam retention, the Turbo SMART 2V with ISO 18 Hydrocyclone serves up to 4 chairs.

#### Details That Matter

- 1-year warranty
- Inverter control for performance and energy efficiency
- SMART self-protection in case of functional anomalies
- ISO 18 Hydrocyclone amalgam retention



1 YEAR WARRANTY



INVERTER CONTROL



AMALGAM RETENTION

#### Turbo SMART 2V with ISO 18 Hydrocyclone

Item Code 035135

##### SPECIFICATIONS

Power 60 HZ 1.5kW 9A  
1PH 230V

Sound Output dB(A) 70

Max Air Flow at l/min 1600

Max Vacuum for Continuous Operation mBar 280

##### DIMENSIONS

Height mm 650

Width mm 540

Depth mm 400

Weight kg 43

#### RELATED PRODUCTS



PULI-JET Gentle 2.0  
Non-foaming  
Disinfectant



Pulse Cleaner



Antifoaming  
Disinfectant Tablets

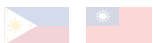

## Tandem Micro SMART | Up to 4 chairs

The most compact of our high-performance SMART suction range, installed in parallel to deliver twice the suction performance. Using Cattani pioneered inverter technology, the Tandem Micro SMART is designed to serve 4 chairs.

### Details That Matter

- 1-year warranty
- Installed in parallel with twice the suction
- Inverter control for performance and energy efficiency
- SMART self-protection in case of functional anomalies
- Compatible with Vento frame
- Amalgam retention option available



Model with ISO 6 Hydrocyclone pictured.



1 YEAR WARRANTY



INVERTER CONTROL



AMALGAM RETENTION

### Tandem Micro SMART

Item Code	035050 x 2 181642 x 2 C-TMSKIT x 1
-----------	--

### SPECIFICATIONS

Power	2 x 1.12kW 8A 1PH 230V 2 x 10A power outlets required
Sound Output dB(A)	67-74
Max Air Flow at l/min	1824
Max Vacuum for Continuous Operation mBar	210
Hydrocyclone Amalgam Retention	No

### DIMENSIONS

Height mm	600
Width mm	1030
Depth mm	640
Weight kg	50

### Frame kit for Tandem Micro SMART

Item Code	C-TMSKIT
-----------	----------

### RELATED PRODUCTS



PULI-JET Gentle 2.0  
Non-foaming  
Disinfectant



Pulse Cleaner



Antifoaming  
Disinfectant Tablets

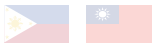

## SMART SUCTION

### Tandem Micro SMART with ISO 6 Hydrocyclone | Up to 4 chairs

The most compact of our high-performance SMART suction range installed in parallel to deliver twice the suction performance. Integrated with ISO 6 Hydrocyclone amalgam retention, the Tandem Micro SMART is designed to serve 4 chairs.

#### Details That Matter

- 1-year warranty
- Installed in parallel with twice the suction
- ISO 6 Hydrocyclone amalgam retention
- Inverter control for performance and energy efficiency
- SMART self-protection in case of functional anomalies
- Compatible with Vento frame



1 YEAR WARRANTY



INVERTER CONTROL



AMALGAM RETENTION

#### Tandem Micro SMART with ISO 6 Hydrocyclone

Item Code 035060 x 2  
C-TMSKIT x 1

#### SPECIFICATIONS

Power	2 x 1.12kW 8A 1PH 230V 2 x 10A power outlets required
Sound Output dB(A)	67-74
Max Air Flow at l/min	1824
Max Vacuum for Continuous Operation mBar	210
Hydrocyclone Amalgam Retention	Yes

#### DIMENSIONS

Height mm	600
Width mm	1030
Depth mm	640
Weight kg	50

#### Frame kit for Tandem Micro SMART

Item Code C-TMSKIT

#### RELATED PRODUCTS



PULI-JET Gentle 2.0  
Non-foaming  
Disinfectant



Pulse Cleaner



Antifoaming  
Disinfectant Tablets



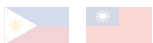

## SMART SUCTION

### Tandem Turbo SMART A | Up to 5 chairs

Designed with inverter technology, the Turbo SMART A units are installed in parallel to deliver twice the suction performance. This model delivers consistent suction to 5 chairs, with the capability of upgrading to Turbo SMART B to serve 8 chairs.

#### Details That Matter

- 1-year warranty
- Installed in parallel with twice the suction
- Capability to upgrade to an 8-chair capacity
- Inverter control for performance and energy efficiency
- SMART self-protection in case of functional anomalies
- Compatible with Vento frame
- Amalgam retention option available



Model with ISO 18 Hydrocyclone pictured.



1 YEAR WARRANTY



INVERTER CONTROL



AMALGAM RETENTION

#### Tandem Turbo SMART A

Item Code 035105 x 2  
C-1TMKIT x1

#### SPECIFICATIONS

Power	2 x 1.5kW 6.5A 1PH 230V 2 x 10A power outlets required
Sound Output dB(A)	72
Max Air Flow at l/min	2860
Max Vacuum for Continuous Operation mBar	210
Hydrocyclone Amalgam Retention	No

#### DIMENSIONS

Height mm	740
Width mm	1250
Depth mm	760
Weight kg	85

#### Frame kit for Tandem Turbo SMART

Item Code C-T1MKIT

#### RELATED PRODUCTS



PULI-JET Gentle 2.0  
Non-foaming  
Disinfectant



Pulse Cleaner



Antifoaming  
Disinfectant Tablets

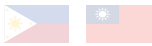

## SMART SUCTION

### Tandem Turbo SMART A with ISO 18 Hydrocyclone | Up to 5 chairs

Integrated with ISO 18 Hydrocyclone amalgam retention, this model is installed in parallel to deliver twice the suction output. This model delivers high-performance suction to 5 chairs, with the capability of upgrading to Turbo SMART B to serve 8 chairs.

#### Details That Matter

- 1-year warranty
- ISO 18 Hydrocyclone amalgam retention
- Installed in parallel with twice the suction
- Capability to upgrade to an 8-chair capacity
- Inverter control for performance and energy efficiency
- SMART self-protection in case of functional anomalies
- Compatible with Vento frame



1 YEAR WARRANTY



INVERTER CONTROL



AMALGAM RETENTION

#### Tandem Turbo SMART A with 2 x ISO 18 Hydrocyclone

Item Code 035115 x 2  
C-1TMKIT x1

#### SPECIFICATIONS

Power	2 x 1.5kW 6.5A 1PH 230V 2 x 10A power outlets required
Sound Output dB(A)	72
Max Air Flow at l/min	2860
Max Vacuum for Continuous Operation mBar	210
Hydrocyclone Amalgam Retention	Yes

#### DIMENSIONS

Height mm	740
Width mm	1250
Depth mm	760
Weight kg	85

#### Frame kit for Tandem Turbo SMART

Item Code C-T1MKIT

#### RELATED PRODUCTS



PULI-JET Gentle 2.0  
Non-foaming  
Disinfectant



Pulse Cleaner



Antifoaming  
Disinfectant Tablets

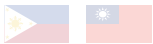

# SMART SUCTION

## Tandem Turbo SMART B | Up to 8 chairs

Designed with Cattani pioneered inverter technology, the Turbo SMART B units are installed in parallel to deliver twice the suction output. Adjusts performance according to suction demands to serve 8 chairs.

### Details That Matter

- 1-year warranty
- Installed in parallel with twice the suction
- Inverter control for performance and energy efficiency
- SMART self-protection in case of functional anomalies
- Compatible with Vento frame
- Amalgam retention option available



Model with ISO 18 Hydrocyclone pictured.



### Tandem Turbo SMART B

Item Code	035105 x 2 035550 x 2 C-1TMKIT x 1
-----------	--

#### SPECIFICATIONS

Power	2 x 1.8kW 7.5A 1PH 230V 2 x 10A power outlets required
Sound Output dB(A)	76.7
Max Air Flow at l/min	3500
Max Vacuum for Continuous Operation mBar	210
Hydrocyclone Amalgam Retention	No

#### DIMENSIONS

Height mm	740
Width mm	1250
Depth mm	760
Weight kg	85

### Frame kit for Tandem Turbo SMART

Item Code	C-T1MKIT
-----------	----------

### RELATED PRODUCTS



PULI-JET Gentle 2.0  
Non-foaming  
Disinfectant



Pulse Cleaner



Antifoaming  
Disinfectant Tablets



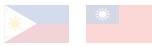

## SMART SUCTION

### Tandem Turbo SMART B with ISO 18 Hydrocyclone | Up to 8 chairs

Integrated with ISO 18 Hydrocyclone amalgam retention, the Turbo SMART B units are installed in parallel to deliver twice the suction output. Adjusts performance according to suction demands to serve 8 chairs.

#### Details That Matter

- 1-year warranty
- ISO 18 Hydrocyclone amalgam retention
- Installed in parallel with twice the suction
- Capability to upgrade to an 8-chair capacity
- Inverter control for performance and energy efficiency
- SMART self-protection in case of functional anomalies
- Compatible with Vento frame



1 YEAR WARRANTY



INVERTER CONTROL



AMALGAM RETENTION

#### Tandem Turbo SMART B with 2 x ISO 18 Hydrocyclone

Item Code	035115 x 2 035550 x 2 C-1TMKIT x 1
-----------	--

#### SPECIFICATIONS

Power	2 x 1.8kW 7.5A 1PH 230V 2 x 10A power outlets required
Sound Output dB(A)	76.7
Max Air Flow at l/min	3500
Max Vacuum for Continuous Operation mBar	210
Hydrocyclone Amalgam Retention	Yes

#### DIMENSIONS

Height mm	740
Width mm	1250
Depth mm	760
Weight kg	85

#### Frame kit for Tandem Turbo SMART

Item Code	C-T1MKIT
-----------	----------

#### RELATED PRODUCTS



PULI-JET Gentle 2.0  
Non-foaming  
Disinfectant



Pulse Cleaner



Antifoaming  
Disinfectant Tablets

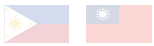

# LARGE PLANT ROOM SOLUTIONS

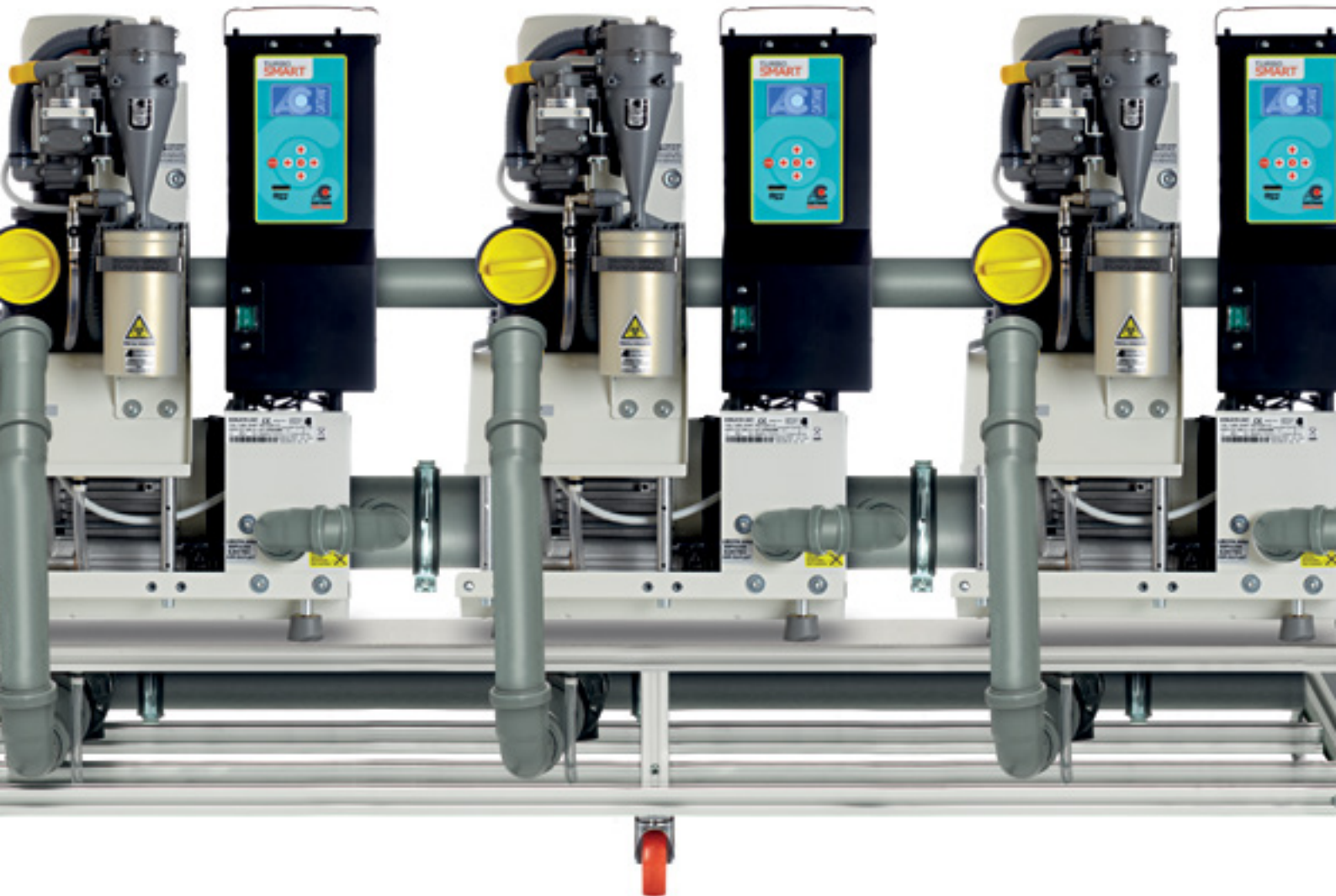



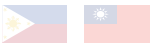

## **MULTI SMART: DESIGNED FOR THE AUSTRALASIAN REGION**

### **12-20 CHAIRS**

Leading innovation without compromising quality, our technical team collaborated with Cattani Italy to co-engineer the new generation of the Multi SMART range, a more compact 12 – 20 chair solution specifically designed for the Australasian region.

The turn-key solution comes in the following configurations:

- T3 Model – up to 12 chairs.
- T4 Model – up to 16 chairs.
- T5 Model – up to 20 chairs.

### **EASY MAINTENANCE, NO DISRUPTIONS**

Installation of Multi SMART system is a simple process with a modular design that allows easy access for maintenance and HEPA filter upgrade onsite.

Each suction module of the system can be isolated to allow for easy servicing while still delivering uninterrupted suction, keeping the dental site running without disruption.

### **CONSISTENT AND RELIABLE SUCTION**

Multi SMART systems are assembled in parallel, and thanks to inverter technology, provide steady and reliable suction with built-in redundancy.

## **MAXI SMART: THE WORLD'S FIRST INTEGRATED SUCTION UNIT FOR LARGE CLINICS**

### **20-60 CHAIRS**

The Maxi SMART system is the world's first integrated suction unit for large clinics, with the capability to provide a constant level of suction at each individual dental chair.

The system is designed to be installed as a modular system, in pairs, with the potential to serve 60 or more chairs. The system units are built with sequential activation intelligence, according to suction demand. Maxi SMART systems are supplied in kit form, with all interconnecting components necessary for parallel installation.

## **AT CATTANI, WE FOCUS ON INNOVATION.**



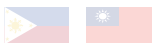

## LARGE PLANT ROOM SOLUTIONS

### Multi SMART T3 | Up to 12 chairs

Designed for the Australasian region, our Italian and Australasian engineering and technical teams worked closely to develop a new solution that is more compact with no compromise on performance. The Multi SMART T3 is designed to serve up to 12 chairs.

#### Details That Matter

- 1-year warranty
- Compact design where space is a premium
- Simple installation and easy access for servicing
- Allows continuous operation even during maintenance
- Designed with built-in redundancy
- Modular design allowing for easy HEPA upgrade onsite
- Amalgam retention option available



Hydrocyclone model shown.



	Multi SMART T3	
Description	Multi SMART T3	Multi SMART T3 with H14 Filtration
Item Code	035105 x 3 035550 x 3 D-JBC23V-20 X 1 C-T3AKIT x 1	035105 x 3 035550 x 3 D-JBC23V-20 X 1 C-T3AHKIT x 1
<b>SPECIFICATIONS</b>		
Power	3 x 1.8kW 7.5A 1PH 230V 1 x 10A (control panel) Total of 4 x 10A power outlets required	3 x 1.8kW 7.5A 1PH 230V 1 x 10A (control panel) Total of 4 x 10A power outlets required
Sound Output dB(A)	78.5	78.5
Max Air Flow at l/min	5100	5100
Max Vacuum for Continuous Operation mBar	210	210
Hydrocyclone Amalgam Retention	No	No
<b>DIMENSIONS</b>		
Height mm	1000	1000
Width mm*	1800	1800
Depth mm	760	760
Weight kg	148	148

\*Dimensions are for frame only. Please allow extra space for installation purposes. Contact our technical team for further information.

#### RELATED PRODUCTS



PULI-JET Gentle 2.0 Non-foaming Disinfectant



Pulse Cleaner



Antifoaming Disinfectant Tablets

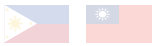

## LARGE PLANT ROOM SOLUTIONS

### Multi SMART T3 with ISO 18 Hydrocyclone | Up to 12 chairs

Designed for the Australasian region, our Italian and Australasian engineering and technical teams worked closely to develop more compact solution. Integrated with ISO 18 Hydrocyclone amalgam retention, the Multi SMART T3 is designed to serve up to 12 chairs.

#### Details That Matter

- 1-year warranty
- ISO 18 Hydrocyclone amalgam retention
- Compact design where space is a premium
- Simple installation and easy access for servicing
- Allows continuous operation even during maintenance
- Designed with built-in redundancy
- Modular design allowing for easy HEPA upgrade onsite



	Multi SMART T3	
Description	Multi SMART T3 with ISO 18 Hydrocyclone	Multi SMART T3 with ISO 18 Hydrocyclone with H14 Filtration
Item Code	035115 x 3 035550 x 3 D-JBC23V-20 X 1 C-T3AKIT x 1	035115 x 3 035550 x 3 D-JBC23V-20 X 1 C-T3AHKIT x 1

#### SPECIFICATIONS

Power	3 x 1.8kW 7.5A 1PH 230V 1 x 10A (control panel) Total of 4 x 10A power outlets required	3 x 1.8kW 7.5A 1PH 230V 1 x 10A (control panel) Total of 4 x 10A power outlets required
Sound Output dB(A)	78.5	78.5
Max Air Flow at l/min	5100	5100
Max Vacuum for Continuous Operation mBar	210	210
Hydrocyclone Amalgam Retention	Yes	Yes

#### DIMENSIONS

Height mm	1000	1000
Width mm*	1800	1800
Depth mm	760	760
Weight kg	148	148

\*Dimensions are for frame only. Please allow extra space for installation purposes. Contact our technical team for further information.

#### RELATED PRODUCTS



PULI-JET Gentle 2.0  
Non-foaming  
Disinfectant



Pulse Cleaner



Antifoaming  
Disinfectant Tablets

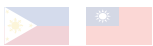

## LARGE PLANT ROOM SOLUTIONS

### Multi SMART T4 | Up to 16 chairs

Designed for the Australasian region, our Italian and Australasian engineering and technical teams worked closely to develop a new solution that is more compact with no compromise on performance. The Multi SMART T4 is designed to serve up to 16 chairs.

#### Details That Matter

- 1-year warranty
- Compact design where space is a premium
- Simple installation and easy access for servicing
- Allows continuous operation even during maintenance
- Designed with built-in redundancy
- Modular design allowing for easy HEPA upgrade onsite
- Amalgam retention option available



Hydrocyclone model shown.



	Multi SMART T4	
Description	Multi SMART T4	Multi SMART T4 with H14 Filtration
Item Code	035105 x 4 035550 x 4 D-JBC24V-20 X 1 C-T4AKIT x 1	035105 x 4 035550 x 4 D-JBC24V-20 X 1 C-T4AHKIT x 1
<b>SPECIFICATIONS</b>		
Power	4 x 1.8kW 7.5A 1PH 230V 1 x 10A (control panel) Total of 5 x 10A power outlets required	4 x 1.8kW 7.5A 1PH 230V 1 x 10A (control panel) Total of 5 x 10A power outlets required
Sound Output dB(A)	79.7	79.7
Max Air Flow at l/min	6800	6800
Max Vacuum for Continuous Operation mBar	210	210
Hydrocyclone Amalgam Retention	No	No
<b>DIMENSIONS</b>		
Height mm	1000	1000
Width mm*	2400	2400
Depth mm	760	760
Weight kg	184	184

\*Dimensions are for frame only. Please allow extra space for installation purposes. Contact our technical team for further information.

#### RELATED PRODUCTS



PULI-JET Gentle 2.0 Non-foaming Disinfectant



Pulse Cleaner



Antifoaming Disinfectant Tablets

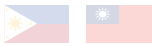

## LARGE PLANT ROOM SOLUTIONS

### Multi SMART T4 with ISO 18 Hydrocyclone | Up to 16 chairs

Designed for the Australasian region, our Italian and Australasian engineering and technical teams worked closely to develop more compact solution. Integrated with ISO 18 Hydrocyclone amalgam retention, the Multi SMART T4 is designed to serve up to 16 chairs.

#### Details That Matter

- 1-year warranty
- ISO 18 Hydrocyclone amalgam retention
- Compact design where space is a premium
- Simple installation and easy access for servicing
- Allows continuous operation even during maintenance
- Designed with built-in redundancy
- Modular design allowing for easy HEPA upgrade onsite



	Multi SMART T4	
Description	Multi SMART T4 with ISO 18 Hydrocyclone	Multi SMART T4 with ISO 18 Hydrocyclone with H14 Filtration
Item Code	035115 x 4 035550 x 4 D-JBC24V-20 X 1 C-T4AKIT x 1	035115 x 4 035550 x 4 D-JBC24V-20 X 1 C-T4AHKIT x 1

#### SPECIFICATIONS

Power	4 x 1.8kW 7.5A 1PH 230V 1 x 10A (control panel) Total of 5 x 10A power outlets required	4 x 1.8kW 7.5A 1PH 230V 1 x 10A (control panel) Total of 5 x 10A power outlets required
Sound Output dB(A)	79.7	79.7
Max Air Flow at l/min	6800	6800
Max Vacuum for Continuous Operation mBar	210	210
Hydrocyclone Amalgam Retention	Yes	Yes

#### DIMENSIONS

Height mm	1000	1000
Width mm*	2400	2400
Depth mm	760	760
Weight kg	184	184

\*Dimensions are for frame only. Please allow extra space for installation purposes. Contact our technical team for further information.

#### RELATED PRODUCTS



PULI-JET Gentle 2.0 Non-foaming Disinfectant



Pulse Cleaner



Antifoaming Disinfectant Tablets



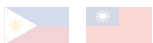

## LARGE PLANT ROOM SOLUTIONS

### Multi SMART T5 | Up to 20 chairs

Designed for the Australasian region, our Italian and Australasian engineering and technical teams worked closely to develop a new solution that is more compact with no compromise on performance. The Multi SMART T5 is designed to serve up to 20 chairs.

### Details That Matter

- 1-year warranty
- Compact design where space is a premium
- Simple installation and easy access for servicing
- Allows continuous operation even during maintenance
- Designed with built-in redundancy
- Modular design allowing for easy HEPA upgrade onsite
- Amalgam retention option available

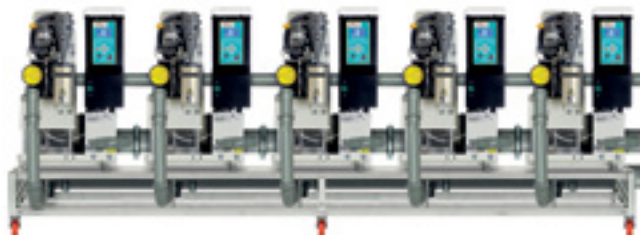

Hydrocyclone model shown.



	Multi SMART T5	
Description	Multi SMART T5	Multi SMART T5 with H14 Filtration
Item Code	035105 x 5 035550 x 5 D-JBC25V-20 X 1 C-T5AKIT x 1	035105 x 5 035550 x 5 D-JBC25V-20 X 1 C-T5AHKIT x 1
<b>SPECIFICATIONS</b>		
Power	5 x 1.8kW 7.5A 1PH 230V 1 x 10A (control panel) Total of 6 x 10A power outlets required	5 x 1.8kW 7.5A 1PH 230V 1 x 10A (control panel) Total of 6 x 10A power outlets required
Sound Output dB(A)	80.7	80.7
Max Air Flow at l/min	8500	8500
Max Vacuum for Continuous Operation mBar	210	210
Hydrocyclone Amalgam Retention	No	No
<b>DIMENSIONS</b>		
Height mm	1000	1000
Width mm*	3000	3000
Depth mm	760	760
Weight kg	220	220

\*Dimensions are for frame only. Please allow extra space for installation purposes. Contact our technical team for further information.

### RELATED PRODUCTS



PULI-JET Gentle 2.0 Non-foaming Disinfectant



Pulse Cleaner



Antifoaming Disinfectant Tablets

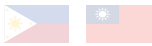

## LARGE PLANT ROOM SOLUTIONS

### Multi SMART T5 with ISO 18 Hydrocyclone | Up to 20 chairs

Designed for the Australasian region, our Italian and Australasian engineering and technical teams worked closely to develop more compact solution. Integrated with ISO 18 Hydrocyclone amalgam retention, the Multi SMART T5 is designed to serve up to 20 chairs.

#### Details That Matter

- 1-year warranty
- ISO 18 Hydrocyclone amalgam retention
- Compact design where space is a premium
- Simple installation and easy access for servicing
- Allows continuous operation even during maintenance
- Designed with built-in redundancy
- Modular design allowing for easy HEPA upgrade onsite



	Multi SMART T5	
Description	Multi SMART T5 with ISO 18 Hydrocyclone	Multi SMART T5 with ISO 18 Hydrocyclone with H14 Filtration
Item Code	035115 x 5 035550 x 5 D-JBC25V-20 X 1 C-T5AKIT x 1	035115 x 5 035550 x 5 D-JBC25V-20 X 1 C-T5AHKIT x 1

#### SPECIFICATIONS

Power	5 x 1.8kW 7.5A 1PH 230V 1 x 10A (control panel) Total of 6 x 10A power outlets required	5 x 1.8kW 7.5A 1PH 230V 1 x 10A (control panel) Total of 6 x 10A power outlets required
Sound Output dB(A)	80.7	80.7
Max Air Flow at l/min	8500	8500
Max Vacuum for Continuous Operation mBar	210	210
Hydrocyclone Amalgam Retention	Yes	Yes

#### DIMENSIONS

Height mm	1000	1000
Width mm*	3000	3000
Depth mm	760	760
Weight kg	220	220

\*Dimensions are for frame only. Please allow extra space for installation purposes. Contact our technical team for further information.

#### RELATED PRODUCTS



PULI-JET Gentle 2.0 Non-foaming Disinfectant



Pulse Cleaner



Antifoaming Disinfectant Tablets

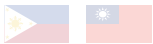

## LARGE PLANT ROOM SOLUTIONS

### Maxi SMART with ISO 60 Hydrocyclone\* | 15-60 chairs

World's first integrated suction system for large clinics, designed to be installed in parallel to serve up to 60 chairs, with the capacity to serve 15 chairs with a single unit. Integrated with Hydrocyclone amalgam retention, the Maxi SMART is built with sequential activation intelligence, according to suction demand.

#### Details That Matter

- 1-year warranty
  - Supplied in kit form, ready for parallel installation
  - ISO 60 Hydrocyclone amalgam retention
  - Sequential activation according to suction demand
  - Noise reduction option available
- \* Maxi SMART is designed as a modular system to be connected in parallel, not to operate as a single unit. Capacity per unit: 12 chairs if the unit is installed on the same level; 15 chairs if the unit is on the level below



	Maxi SMART	
Description	Maxi SMART with ISO 60 Hydrocyclone	Maxi SMART with ISO 60 Hydrocyclone with H14 Filtration
Item Code	035210 035200 Unit without Hydrocyclone	035211
<b>SPECIFICATIONS</b>		
Power	11.8kW 25A 3PH 400V	11.8kW 25A 3PH 400V
Sound Output dB(A)	77	77
Max Air Flow at l/min	5000	5000
Max Vacuum for Continuous Operation mBar	240	240
Hydrocyclone Amalgam Retention	Yes (035210 only)	Yes
<b>DIMENSIONS</b>		
Height mm	1490	1490
Width mm	708	708
Depth mm	1037	1037
Weight kg	215	215

#### RELATED PRODUCTS



PULI-JET Gentle 2.0  
Non-foaming  
Disinfectant



Pulse Cleaner



Antifoaming  
Disinfectant Tablets

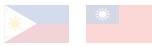

## LARGE PLANT ROOM SOLUTIONS

### Maxi SMART with ISO 60 Hydrocyclone and Acoustic Cover\* | 15-60 chairs

World's first integrated suction system for large clinics, designed to be installed in parallel to serve up to 60 chairs, with the capacity to serve 15 chairs with a single unit. Integrated with Hydrocyclone amalgam retention, with acoustic cover.

#### Details That Matter

- 1-year warranty
  - Acoustic cover for low noise
  - Supplied in kit form, ready for parallel installation
  - ISO 60 Hydrocyclone amalgam retention
  - Sequential activation according to suction demand
- \* Maxi SMART is designed as a modular system to be connected in parallel, not to operate as a single unit. Capacity per unit: 12 chairs if the unit is installed on the same level; 15 chairs if the unit is on the level below



	Maxi SMART	
Description	Maxi SMART with ISO 60 Hydrocyclone and Acoustic Cover	Maxi SMART with ISO 60 Hydrocyclone and Acoustic Cover with H14 Filtration
Item Code	035215 035205 Unit without Hydrocyclone	035216

SPECIFICATIONS		
Power	11.8kW 25A 3PH 400V	11.8kW 25A 3PH 400V
Sound Output dB(A)	68	68
Max Air Flow at l/min	5000	5000
Max Vacuum for Continuous Operation mBar	240	240
Hydrocyclone Amalgam Retention	Yes (035215 only)	Yes

DIMENSIONS		
Height mm	1490	1490
Width mm	708	708
Depth mm	1037	1037
Weight kg	270	270

#### RELATED PRODUCTS



PULI-JET Gentle 2.0  
Non-foaming  
Disinfectant



Pulse Cleaner

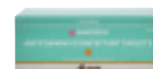

Antifoaming  
Disinfectant Tablets

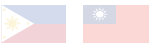

# COMPACT PLANT ROOM SOLUTIONS



INVERTER  
CONTROL



AMALGAM  
RETENTION

## SPACE IS A PREMIUM

Space is valuable and, in many practices, strictly limited. There can also be issues with noise upsetting staff, patients and even neighbours. Cattani understands that, and provides compact solutions in a variety of configurations and noise-reducing options that can even do away with the need for a plant room entirely.





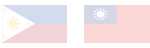

## Blok-Jet Silent 1 & 2: the self-contained plant solutions | 1-2 and 3-4 chairs

The Blok-Jet Silent solution is to stack the units inside their own cabinet. Serves up to four chairs and is ultra-quiet, it is an excellent option when noise mitigation is a priority. The cabinet also has a very small footprint and stands on caster wheels, for ease of positioning and service.

### Details That Matter

- Serves up to four chairs
- Compact – the size of a fridge
- Ultra-quiet
- Mobile – it stands on lockable wheels
- Cabinet doors also lockable
- External display panel shows compressor and suction status



Blok-Jet Silent 2 pictured.

INDENT ITEM	Blok-Jet Silent 1	Blok-Jet Silent 2
	Blok-Jet Silent 1 AC200 Compressor & Micro SMART with Hydrocyclone	Blok-Jet Silent 2 AC300 Compressor & Turbo SMART B with Hydrocyclone
Item Code	Upon Request	Upon Request
<b>SPECIFICATIONS</b>		
Compressor	AC200	AC300
Suction	Micro SMART	Turbo SMART B
Sound Output dB(A)	57.5	55
<b>DIMENSIONS</b>		
Height mm	1583	1935
Width mm	727	760
Depth mm	577	650
Weight kg	220	280

### RELATED PRODUCTS



PULI-JET Gentle 2.0  
Non-foaming  
Disinfectant



Pulse Cleaner



Antifoaming  
Disinfectant Tablets

## Vento solutions: the ultimate space saver for up to eight chairs

Designed and developed by Cattani Australasia, the Vento approach is to stack the suction unit and the compressor on an engineered frame, halving the floor space. This is the perfect plant configuration for practices where space is tight, and a dedicated plant room is a luxury. Vento can be configured to service up to eight chairs. Units with noise reducing options are also available.

### Vento solutions can incorporate:

- Micro SMART
- Turbo SMART
- Noise-reducing SMART Cube suction units
- Our entire compressor range, including CAD/CAM
- Acoustic compressor hoods [Q Series]
- Amalgam retention



FRAME 1  
Example with AC200 and Turbo SMART with Hydrocyclone



FRAME 2  
Example with AC600 and Tandem Turbo SMART with Hydrocyclone

### How to configure your Vento solution

1. Select your Compressor (pages 12–21)
2. Select your Suction (pages 47–67)
3. Select your Vento frame based on your compressor size (except when choosing Turbo SMART Cube suction system)\*
4. Combine the pricing for your compressor, suction, and Vento frame to determine the overall price of the Vento solution.

	FRAME 1 (Turbo SMART)	FRAME 1B (Turbo SMART Cube)	FRAME 2
Order number	JVT0000	JVTTSC0	JCSTTS
Compatibility	AC100, AC200 & AC300 Series	AC100, AC200 & AC300 Series	Compatible with AC400 & AC600 Series
<b>DIMENSIONS</b>			
Height mm	820	820	950
Width mm	695	695	1280
Depth mm	490	610	600

\*Frames are only sold as part of a complete Vento configuration. For the individual sale of the frame component, contact your local Business Development Manager.

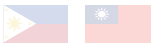

# CLASSIC SUCTION

## DRY SUCTION: PROVEN CATTANI TECHNOLOGY

### BUILT TO LAST

Cattani dry suction motors deliver high volume airflow with high pressure, even with a large suction tip. Our separators, control panels, and vacuum relief valves are all you need if dry suction is your preferred option.

Cattani dry suction motors are made from quality materials and built to last. The machines are incredibly easy to operate, and the mechanics and circuitry are easy to maintain:

- 1-7 chairs
- Single or three-phase, depending on the unit
- Noise reduction options available
- Units designed to be installed close to the dental unit

## TURBO-JET: SIMPLY SAFE SUCTION

### HIGH FLOW PERFORMANCE

Turbo-Jet is a powerful and effective aspiration and air/fluid separation single-chair system that is made for continuous use. Using a robust Uni-Jet 75 suction motor with centrifugal pump, it has a maximum negative pressure of 130 mBar and maximum air flow rate 650 l/min, with automatic drainage.

### COMPACT SOLUTION

Turbo-Jet comes in a variety of configurations and is small enough to fit into a ventilated cupboard close to the dental chair, while the separator may be placed close to the chair. With proper care and simple maintenance, Turbo-Jet will give many years of reliable service.

## ASPI-JET: MOBILE OR BACKUP SUCTION SYSTEM

### PLUG AND PLAY

If you need a simple, safe, and mobile chairside aspirator for a single chair, Aspi-Jet 6 is for you – just plug it in and turn it on. Aspi-Jet 6 is designed for continuous use and reliable high flow, medium vacuum, and effective air/fluid separation.

### MOBILE RELIABILITY

Aspi-Jet 6 is on wheels for easy transfer from surgery to surgery. It is a handy back-up system and a good option where it is difficult to get plumbing to the dental unit.

Powered by a robust Uni-Jet 75 motor, the Aspi-Jet has a maximum negative pressure of 130 mBar with maximum air flow rate 650 l/min.

The Aspi-Jet range includes plumbed versions in the Aspi-Jet 7, 8 and 9 models that include auto-drain options, all with foam-lined cabinet for quietness.



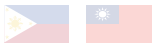

## MOBILE SUCTION



Uni-Jet 6 with Bacterial Filter:  
Filter removes solid and biological particles down to 0.01 micron.



Aspi-Jet 6		
Description	Unit without Bacterial Filter	Unit with Bacterial Filter
Item Code	010015	010015 C-0006B0-KIT

SPECIFICATIONS		
Sound Output dB(A)	60	60
Max Air Flow at l/min	650	650
Max Vacuum for Continuous Operation mBar	130	130
Tank Size (litres)	4	4

DIMENSIONS		
Height mm	750	750
Width mm	325	325
Depth mm	420	420

Manual drain 4 litre canister capacity.



INDENT ITEMS	Aspi-Jet 7	Aspi-Jet 8	Aspi-Jet 9
Item Code	010022	010032	010042
SPECIFICATIONS			
Sound Output dB(A)	60	60	60
Max Air Flow at l/min	650	650	650
Max Vacuum for Continuous Operation mBar	130	130	130
DIMENSIONS			
Height mm	750	750	750
Width mm	325	325	325
Depth mm	420	420	520
	Automatic drain pump	Automatic drain pump & cup filler	Automatic drain pump, cup filler & spittoon
	Requires plumbing to waste	Requires plumbing to waste	Requires plumbing to waste
		Requires water supply	Requires water & air supply



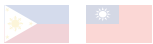

## Uni-Jet 75 Single Phase | 1 chair



Uni-Jet 75	
Description	Single Phase
Item Code	020330
SPECIFICATIONS	
Power	60 HZ 0.4kW 3.5A 1PH 220V
Sound Output dB(A)	62
Max Air Flow at l/min	1250
Max Vacuum for Continuous Operation mBar	130
DIMENSIONS	
Height mm	275
Width mm	232
Depth mm	246

Unit with Control Panel	
Item Code	020330 + 020270

**Accessories**  
160562 Silencer – L400mm x Dia. 80mm (30mm ports)

## Uni-Jet 75 2V Single Phase | 1 chair



Uni-Jet 75 2V	
Description	Single Phase
Item Code	020373
SPECIFICATIONS	
Power	60 HZ 0.9kW 6A 1PH 220V
Sound Output dB(A)	64
Max Air Flow at l/min	1330
Max Vacuum for Continuous Operation mBar	270
DIMENSIONS	
Height mm	275
Width mm	246
Depth mm	491

Unit with Control Panel	
Item Code	020373 + 020630

**Accessories**  
160562 Silencer – L400mm x Dia. 80mm (30mm ports)

## Tecno-Jet Single Phase | 2-3 chairs



Tecno-Jet	
Description	Single Phase
Item Code	020625
SPECIFICATIONS	
Power	60 HZ 0.75kW 8.7A 1PH 220V
Sound Output dB(A)	64
Max Air Flow at l/min	2000
Max Vacuum for Continuous Operation mBar	140
DIMENSIONS	
Height mm	320
Width mm	310
Depth mm	310
Unit with Control Panel	
Item Code	020625 + 020630
Accessories	
160564 Silencer – L400mm x Dia. 160mm (50mm ports)	
160682 Vacuum Relief Valve	

## Tecno-Jet 2V Single Phase | 2-3 chairs



Tecno-Jet 2V	
Description	Single Phase
Item Code	020921
SPECIFICATIONS	
Power	60 HZ 1.1kW 8.7A 1PH 220V
Sound Output dB(A)	65
Max Air Flow at l/min	2170
Max Vacuum for Continuous Operation mBar	200
DIMENSIONS	
Height mm	320
Width mm	310
Depth mm	550
Unit with Control Panel	
Item Code	020921 + 020850
Accessories	
160564 Silencer – L400mm x Dia. 160mm (50mm ports)	
160682 Vacuum Relief Valve	

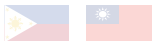

## Flux-Jet 1.6kW Single Phase | 4 chairs



Flux-Jet 1.6kW	
Description	Single Phase
Item Code	020711
SPECIFICATIONS	
Power	60 HZ 1.6kW 11A 1PH 220V
Sound Output dB(A)	68.5
Max Air Flow at l/min	3300
Max Vacuum for Continuous Operation mBar	150
DIMENSIONS	
Height mm	350
Width mm	340
Depth mm	410

Unit with Control Panel	
Item Code	020711 + 020850
Accessories	
160564 Silencer – L400mm x Dia. 160mm (50mm ports)	
160680 Vacuum Relief Valve	

## Flux-Jet 2V 3 Phase | 4 chairs



Flux-Jet 2V	
Description	3 Phase
Item Code	020717
SPECIFICATIONS	
Power	60 HZ 2.6kW 6.3A 3PH 400V
Sound Output dB(A)	72
Max Air Flow at l/min	3300
Max Vacuum for Continuous Operation mBar	230
DIMENSIONS	
Height mm	350
Width mm	340
Depth mm	590

Unit with Control Panel	
Item Code	020717 + 021050
Accessories	
160564 Silencer – L400mm x Dia. 160mm (50mm ports)	
160640 Vacuum Relief Valve	

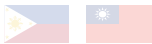

## Medio-Jet Blower 2.6kW 3 Phase | 7 chairs



### Medio-Jet Blower 3kW

Description	3 Phase
Item Code	021036

#### SPECIFICATIONS

Power	60 HZ 2.6kW 6.4A 3PH 400V
Sound Output dB(A)	76
Max Air Flow at l/min	5000
Max Vacuum for Continuous Operation mBar	230

#### DIMENSIONS

Height mm	420
Width mm	400
Depth mm	335

### Unit with Control Panel

Item Code	021036 + 021050
-----------	-----------------

#### Accessories

- 169373 Silencer – L265mm x Dia. 90mm (50mm ports)
- 160692 Vacuum Relief Valve

## Medio-Jet 2V 3 Phase | 7 chairs



### Medio-Jet 2V

Description	3 Phase
Item Code	020928

#### SPECIFICATIONS

Power	60 HZ 4kW 12A 3PH 400V
Sound Output dB(A)	77
Max Air Flow at l/min	4830
Max Vacuum for Continuous Operation mBar	245

#### DIMENSIONS

Height mm	420
Width mm	400
Depth mm	705

### Unit with Control Panel

Item Code	020928 + 021110
-----------	-----------------

#### Accessories

- 169373 Silencer – L265mm x Dia. 90mm (50mm ports)
- 160692 Vacuum Relief Valve



## Uni-Jet 75 in Cover | 1 chair

Uni-Jet 75	
Description	In Cover
Item Code	Upon Request
SPECIFICATIONS	
Power	60 HZ 0.4kW 3.5A 1PH 220V
Sound Output dB(A)	58
Max Vacuum for Continuous Operation mBar	130
DIMENSIONS	
Height mm	330
Width mm	320
Depth mm	280
Unit with Control Panel	
Item Code	020274 + 020270
Accessories	
160562 Silencer – L400mm x Dia. 80mm (30mm ports)	

## Uni-Jet 75 in Cover with Control | 1 chair



Uni-Jet 75	
Description	In Cover with Control
Item Code	020291
SPECIFICATIONS	
Power	60 HZ 0.4kW 3.5A 1PH 220V
Sound Output dB(A)	58
Max Vacuum for Continuous Operation mBar	130
DIMENSIONS	
Height mm	330
Width mm	320
Depth mm	280
Accessories	
160562 Silencer – L400mm x Dia. 80mm (30mm ports)	



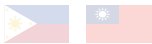

# CLASSIC SUCTION

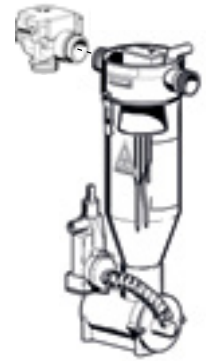

## Continuous Suction Separator with Bracket – Multi Surgery

Continuous Suction Separator				
Description	Multi Surgery Unit with Bracket (90 degree)	Multi Surgery Unit without Bracket (180 degree)	Single Surgery Unit with Bracket (90 degree)	Single Surgery Unit with Bracket (180 degree)
Item Code	020995	020997	021002	021003
<b>SPECIFICATIONS</b>				
Power	24V	24V	24V	24V
<b>DIMENSIONS</b>				
Height mm	350	350	350	350
Width mm	250	250	250	250
Depth mm	100	100	100	100



## Continuous Suction Separator in Cover

Continuous Suction Separator in Cover	
Description	Single Surgery Unit
Item Code	020998
<b>SPECIFICATIONS</b>	
Power	24V
<b>DIMENSIONS</b>	
Height mm	350
Width mm	250
Depth mm	100



## Turbo-Jet 1 Compact | 1 chair

Turbo-Jet 1 Compact	
Item Code	Upon Request
SPECIFICATIONS	
Power	60 HZ 0.52kW 4.6A 1PH 220V
Sound Output dB(A)	61
Max Vacuum for Continuous Operation mBar	130
Max Air Flow l/min	650
DIMENSIONS	
Height mm	504
Width mm	399
Depth mm	275



## Turbo-Jet 1 Compact with ISO 4 Hydrocyclone | 1 chair

Turbo-Jet 1 Compact with ISO 4 Hydrocyclone	
Item Code	Upon Request
SPECIFICATIONS	
Power	60 HZ 0.52kW 4.6A 1PH 220V
Sound Output dB(A)	61
Max Vacuum for Continuous Operation mBar	130
Max Air Flow l/min	650
Hydrocyclone Amalgam Retention	Yes
DIMENSIONS	
Height mm	504
Width mm	399
Depth mm	275

## Turbo-Jet 1 | 1 chair



Turbo-Jet 1	
Item Code	026116
<b>SPECIFICATIONS</b>	
Power	60 HZ 0.52kW 4.6A 1PH 220V
Sound Output dB(A)	61
Max Vacuum for Continuous Operation mBar	130
Max Air Flow l/min	650
<b>DIMENSIONS</b>	
Height mm	399
Width mm	440
Depth mm	380

## Turbo-Jet 1 with ISO 4 Hydrocyclone | 1 chair



Turbo-Jet 1 with ISO 4 Hydrocyclone	
Item Code	Upon Request
<b>SPECIFICATIONS</b>	
Power	60 HZ 0.52kW 4.6A 1PH 220V
Sound Output dB(A)	61
Max Vacuum for Continuous Operation mBar	130
Max Air Flow l/min	650
Hydrocyclone Amalgam Retention	Yes
<b>DIMENSIONS</b>	
Height mm	399
Width mm	440
Depth mm	410



## Turbo-Jet 1 Modular | 1 chair

	Turbo-Jet 1 Modular	Turbo-Jet 1 Modular with Cover	Turbo-Jet 1 Modular with Acoustic Cover
Item Code	026112	026152	026172
<b>SPECIFICATIONS</b>			
Power	60 HZ 0.52kW 4.6A 1PH 220V	60 HZ 0.52kW 4.6A 1PH 220V	60 HZ 0.52kW 4.6A 1PH 220V
Sound Output dB(A)	61	58	52
Max Vacuum for Continuous Operation mBar	130	130	130
Max Air Flow l/min	650	650	650
<b>DIMENSIONS</b>			
Height mm	360	420	360
Width mm	540	565	540
Depth mm	350	320	350



## Turbo-Jet 1 Modular with ISO 4 Hydrocyclone | 1 chair

	Turbo-Jet 1 Modular with ISO 4 Hydrocyclone	Turbo-Jet 1 Modular with ISO 4 Hydrocyclone and Cover	Turbo-Jet 1 Modular with ISO 4 Hydrocyclone and Acoustic Cover
Item Code	Upon Request	Upon Request	Upon Request
<b>SPECIFICATIONS</b>			
Power	60 HZ 0.52kW 4.6A 1PH 220V	60 HZ 0.52kW 4.6A 1PH 220V	60 HZ 0.52kW 4.6A 1PH 220V
Sound Output dB(A)	61	58	52
Max Vacuum for Continuous Operation mBar	130	130	130
Max Air Flow l/min	650	650	650
Hydrocyclone Amalgam Retention	Yes	Yes	Yes
<b>DIMENSIONS</b>			
Height mm	380	420	465
Width mm	540	640	640
Depth mm	450	320	320



## Turbo-Jet 2 Modular | 1 chair

	Turbo-Jet 2 Modular	Turbo-Jet 1 Modular with Cover	Turbo-Jet 1 Modular with Acoustic Cover
Item Code	026212	026252	026272
<b>SPECIFICATIONS</b>			
Power	60 HZ 0.92kW 7.1A 1PH 230V	60 HZ 0.92kW 7.1A 1PH 230V	60 HZ 0.92kW 7.1A 1PH 230V
Sound Output dB(A)	65	61	56
Max Vacuum for Continuous Operation mBar	230	230	230
Max Air Flow l/min	650	650	650
<b>DIMENSIONS</b>			
Height mm	380	470	510
Width mm	560	560	560
Depth mm	440	430	480

## Mono-Jet | 1 chair



	Mono-Jet 1 Alpha (Square Corners)	Mono-Jet 1 Beta (Rounded Corners)
Item Code	010053	010075
<b>SPECIFICATIONS</b>		
Power	60 HZ 0.4kW 3.5A 1PH 220V	60 HZ 0.4kW 3.5A 1PH 220V
Sound Output dB(A)	59	59
Max Vacuum for Continuous Operation mBar	130	130
Max Air Flow l/min	650	650
<b>DIMENSIONS</b>		
Height mm	440	440
Width mm	520	520
Depth mm	285	285



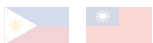

# SUCTION ACCESSORIES

## Surgical Suction Tip #9

Dental aspiration tip with a smaller diameter for precise evacuation of fluids from the oral cavity. The design makes it easy to use and ensures effective aspiration during dental procedures. Each pack contains 3 suction tips.

- Autoclavable (Type B) at 134°Celsius, 2.1 bar for 10 minutes
- Reusable for 100 sterilisation cycles
- Sterilise prior to use

Order Number	Size	Pack Qty
040230	Suits 11mm hose terminal	1



## Surgical Suction Tip #21

Dental aspiration tip with a smaller diameter for precise evacuation of fluids from the oral cavity. The design makes it easy to use and ensures effective aspiration during dental procedures. Each pack contains 3 suction tips.

- Curved design
- Autoclavable (Type B) at 134°Celsius, 2.1 bar for 10 minutes
- Reusable for 100 sterilisation cycles
- Sterilise prior to use

Order Number	Size	Pack Qty
040257	Suits 11mm hose terminal	1



## High Volume Evacuator (HVE) Tip #11

Recommended for aspirators with high airflow and low head. The design of the nebulisation and interceptor makes it easy to use and ensures effective aspiration during dental procedures where evacuation is required. Each pack contains 3 suction tips.

- Autoclavable (Type B) at 134°Celsius, 2.1 bar for 10 minutes
- Reusable for 100 sterilisation cycles
- Sterilise prior to use

Order Number	Size	Pack Qty
040260	Suits 16mm hose terminal	1



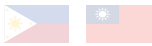

## SUCTION ACCESSORIES

### High Volume Evacuator (HVE) Tip #17

This nebulisation and spray interceptor is ideal for aspirators with moderate airflow. The low noise design makes it easy to use and ensures effective spray interception during dental procedures where high volume evacuation is required. Each pack contains 3 suction tips.

- Quiet
- Angled design
- Autoclavable (Type B) at 134°Celsius, 2.1 bar for 10 minutes
- Reusable for 100 sterilisation cycles
- Sterilise prior to use

Order Number	Size	Pack Qty
040250	Suits 11mm hose terminal	1



### High Volume Evacuator (HVE) Tip #20

The HVE #20 tip is recommended for aspirators with high airflow and low head. The curved design is easy to use and ensures effective aspiration and spray interception during dental procedures where high volume evacuation is required. Each pack contains 3 suction tips.

- Curved design
- Autoclavable (Type B) at 134°Celsius, 2.1 bar for 10 minutes
- Reusable for 100 sterilisation cycles
- Sterilise prior to use

Order Number	Size	Pack Qty
040255	Suits 16mm hose terminal	1



### High Volume Evacuator (HVE) Tip #22

This nebulisation and spray interceptor is ideal for aspirators with moderate airflow. The curved it is easy to use and ensures effective aspiration and spray interception during dental procedures high volume evacuation is required. Each pack contains 3 suction tips.

- Reduces sound vibration
- Curved design
- Autoclavable (Type B) at 134°Celsius, 2.1 bar for 10 minutes
- Reusable for 100 sterilisation cycles
- Sterilise prior to use

Order Number	Size	Pack Qty
040258	Suits 16mm hose terminal	1



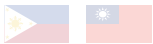

## SUCTION ACCESSORIES

### Cleaning Brush for Surgical Suction Tips – Small

Designed for cleaning and scrubbing of dental suction tips. Effectively reaches all parts of the to clean prior to autoclaving. Suitable for small tips (11mm).

Order Number	Size	Pack Qty
040810	Suits 11mm suction tips	1



### Cleaning Brush For Surgical Suction and HVE Tips – Large

Designed for cleaning and scrubbing of dental suction tips and high volume evacuator tips. Effectively all parts of the internal surface to clean prior to autoclaving. Suitable for large tips

Order Number	Size	Pack Qty
040820	Suits 16mm suction tips	1



### Funnel Spittoon

Flexible in its design the Cattani funnel spittoon is designed to fit into both the 11mm and the 16mm hose terminals.

- Autoclavable (Type B) at 134°Celsius, 2.1 bar for 10 minutes
- Reusable for 50 sterilisation cycle

Order Number	Size	Colour	Pack Qty
040502	Suits 11mm and 16mm hose terminals	White	1



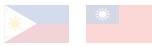

## SUCTION ACCESSORIES

### Saliva Ejector Adaptor

Designed to suit most saliva ejector tips to fit the 11mm or 16mm hose terminal.

- Autoclavable (Type B) at 134°Celsius, 2.1 bar for 10 minutes
- Reusable for 50 sterilisation cycles

Order Number	Size	Colour	Pack Qty
040515	Suits 11mm and 16mm hose terminals	Grey	1



### Tip Reducer

The tip reducer reduces the internal diameter from 16mm to 11mm hose terminals to suit insertion of 11mm suction and high volume evacuator tips. Suitable for use with the Cattani Surgical Suction Tip #9 and High Volume Evacuator (HVE) Tip #17.

- Autoclavable (Type B) at 135°Celsius, 2.1 bar for 10 minutes

Order Number	Size	Colour	Pack Qty
040521	Reduces diameter from 16 to 11mm	Grey	1



### Hose Terminal – Small (11mm)

Designed to work with 11mm suction tips and the 11mm high volume evacuation tips.

- Autoclavable (Type B) at 134°Celsius, 2.1 bar for 10 minutes
- Reusable for 50 sterilisation cycles

Order Number	Size	Colour	Pack Qty
040631	11mm	Grey	1



### Hose Terminal – Large (16mm)

Designed to work with 16mm suction tips and the 16mm high volume evacuation tips.

- Autoclavable (Type B) at 134°Celsius, 2.1 bar for 10 minutes
- Reusable for 50 sterilisation cycles

Order Number	Size	Colour	Pack Qty
040641	16mm	Grey	1



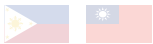

## SUCTION ACCESSORIES

### Hose End Connector – Small (11mm)

Replacement hose end connector for use with the 11mm Hose Terminal. Also used to connect to manual and pneumatic tip supports.

- Autoclavable (Type B) at 134°Celsius, 2.1 bar for 10 minutes
- Reusable for 50 sterilisation cycles

Order Number	Size	Colour	Pack Qty
203470	11mm	Grey	1



### Slide Closer

Replacement slide closer for use with the Hose Terminal.

Order Number	Size	Colour	Pack Qty
205368	11mm	Grey	1
205369	16mm	Grey	1





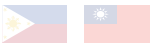

## SUCTION ACCESSORIES

### Manual Tip Support with Filter

Three hose terminal hanger with manual closure of terminals. Includes manifold with filter, 3 spiral tubes with terminals (1 x 16mm, 2 x 11mm), accessories and additional flat spiral tube. Dimensions without hoses or terminals: Height 118mm x Width 135mm x Depth 105mm.



Order Number	Entry Side	Colour	Pack Qty
030021	Rear	Grey	1

### Pneumatic Tip Support with Filter

Two hose terminal hanger with automatic pneumatic closure of terminals. Includes manifold with filter, 2 x silicone tubes with terminals (1 x 11mm and 1 x 16mm), fastening plate, accessories and spiral tube. Dimensions without hoses or terminals: Height 118mm x Width 135mm x Depth 105mm.



Order Number	Colour	Pack Qty
030031	Grey	1

### Pneumatic Tip Support with filter and Triplex Holder

Two hose terminal hanger with automatic pneumatic closure of terminals. Also includes triplex holder. Includes an element filter. Dimensions without hoses or terminals: Height 118mm x Width 148mm x Depth 105mm.



Order Number	Colour	Pack Qty
030056	Grey	1

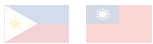

## SUCTION ACCESSORIES

### Triplex Syringe Holder

Triplex syringe holder with the flexibility of being either cabinet mounted or fitted to the side of the Cattani Pneumatic Tip Support. Complete with adapters included to cater for various sized syringes.



Order Number	Colour	Pack Qty
030081	Grey	1

### Saliva Ejector Holder

Flexible installation options of being cabinet mounted or fitted to the side of the Cattani Pneumatic Tip Support. Complete with a micro-switch and a range of reducers to cater for various sized hoses.



Order Number	Colour	Pack Qty
030371	Grey	1

### Extension Segment Arm – Manual Tip Support

Extension arm suitable for use with the Cattani Manual Tip Support.

- Double segment arm extends: Minimum 50mm to Maximum 470mm
- Note: Extension lengths do not include the tip support depth.



Order Number	Arm Extension	Pack Qty
040030	Single	1
040050	Double	1

### Extension Segment Arm – Pneumatic Tip Support

Extension arm suitable for use with the Cattani Pneumatic Tip Support that can be wall or cabinet mounted.

- Single segment arm extends: Maximum 300mm
- Double segment arm extends: Maximum 500mm
- Maximum extension to double segment only

Note: Extension lengths do not include the tip support depth.



Order Number	Arm Extension	Pack Qty
040021	Single	1
040040	Double	1



## SUCTION ACCESSORIES

NOTE: If a 25m roll is required, please add "FR" to end of the item code.

### Spiral Hose — Small Sizes

Order Number	Size	Colour
040850	17mm	Black
040860	17mm	Grey
040910	14mm	Black
040890	11mm	Grey



### Spiral Hose — Medium Sizes

Order Number	Size	Colour
040940	20mm	Black
040970	25mm	Black
041010	30mm	Black



### Spiral Hose — Large Sizes

Order Number	Size	Colour
041040	40mm	Black
230106	50mm	Grey



### Silicone Hose

Order Number	Size	Colour
040869	17mm	Grey
040904	11mm	Grey



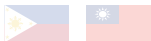

## SUCTION ACCESSORIES

### Control Panel – Classic Suction

The classic suction control panels include an off delay timer that avoids rapid stop/start of the motor.

Order Number	Dimensions	Model Suited
020270	Height 400mm Width 300mm Depth 170mm	Uni-Jet 1 Phase
020630	Height 400mm Width 300mm Depth 170mm	Tecno-Jet 1 Phase
020850	Height 400mm Width 300mm Depth 170mm	Flux-Jet 1 Phase
021050	Height 400mm Width 300mm Depth 170mm	All 3 Phase Units



### Vacuum Relief Valve – Tecno-Jet

Limits maximum vacuum to not overload the suction motor.

Order Number	Model Suited
160682	Tecno-Jet



### Vacuum Relief Valve – Flux-Jet

Limits maximum vacuum to not overload the suction motor.

Order Number	Model Suited
160680	Flux-Jet



### Vacuum And Heat Relief Valve – Flux-Jet 2V

Limits maximum vacuum to not overload the suction motor.

Order Number	Model Suited
160640	Flux-Jet 2V



### Vacuum Relief Valve – Medio-Jet

Limits maximum vacuum to not overload the suction motor.

Order Number	Model Suited
160691	Medio-Jet



### Vacuum Relief Valve – Maxi-Jet 2S

Heat and vacuum relief valve for Tecno-Jet 0.75kW 160639, Flux-Jet 1.1kW 160647, Flux-Jet 1.5kW 160640

Order Number
160683

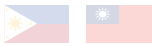

## SUCTION ACCESSORIES

### Silencer for Turbo SMART

Order Number	Dimensions	Pack Qty
160566	Length 440mm Diameter 100mm (50mm ports)	1



### Silencer for Uni-Jet

Designed to reduce noise by 2dB (A).

Order Number	Dimensions	Pack Qty
160562	Length 400mm Diameter 80mm (30mm ports)	1



### Silencer for Tecno-Jet and Flux-Jet

Designed to reduce noise by 2dB (A).

Order Number	Dimensions	Pack Qty
160564	Length 440mm Diameter 160mm (50mm ports)	1



### Silencer for Medio-Jet

Designed to reduce noise by 2dB (A).

Order Number	Dimensions	Pack Qty
169373	Length 265mm Diameter 90mm (50mm ports)	1



### Genuine Cattani Air Flow Meter

Service technician tool to measure high volume evacuation terminals within the clinic ensuring appropriate levels of suction at each chair.

Order Number	Description	Pack Qty
040840	Air flow meter, case & accessories	1



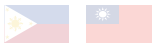

## SUCTION ACCESSORIES

### EP Suction Isolation Valve

This 24V isolation valve is designed for use with all types of suction systems to isolate each chair's suction.



Order Number	Dimensions	Pack Qty
024150	Height 68mm Width 85mm Depth 70mm	1

### Manual Air Injector Valve – Classic Suction

A manual air injector valve that is designed to be installed at the end of the suction line. Allows air to enter the suction line when it is working at a closed head, keeping fluids flowing.



Order Number	Pack Qty
203770	1

### Spittoon Drain Valve

Automatic valve that connects the spittoon waste to the suction system. Requires 24V AD/DC supply. Valve is activated when fluid is sensed by the electronic level sensing probes. Valve also activates suction system if not already running.

- Post Box - installation inside the post box.
- Universal - installation in the floor box of dental unit.

Order Number	Dimensions	Pack Qty
021960	Post Box – Height 180mm Width 47mm Depth 93mm	1
021974	Universal – Height 180mm Width 110.7mm Depth 100mm	1





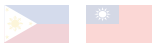

## SUCTION ACCESSORIES

### Bacterial Filter – Aspi-Jet & Turbo Jet

Filters exhaust suction air prior to releasing to the atmosphere. Recommended when exhaust air has the potential to be released into areas accessible by people. Suitable for Aspi-Jet and Turbo-Jet 1 and 2.

- Removes 99.9% of particles
- Removes bacterial particles down to 0.01 micron
- Odour removal via activated carbon
- 30mm port connection (refer hose connection page for exhaust hoses)
- Filter should be replaced approximately every 12 months



Order Number	Description	Size	Pack Qty
042010	Filter Housing and Filter	Height 225mm (excludes port protusion) Diameter 140mm	1

### HEPA H14 Filter – 1-4 Surgeries

Filters exhaust suction air prior to releasing to the atmosphere. Recommended when exhaust air has the potential to be released into areas accessible by people. Suitable for Turbo SMART, Micro SMART and selected dry suction units, please contact Cattani customer service team for suitable recommendations.

- 99.975% efficiency at 0.3 micron
- Filter should be replaced approximately every 12 months
- Filters 90m<sup>3</sup>/h
- 63mm port connection (refer hose connection page for suitable exhaust hoses)



Order Number	Description	Size	Pack Qty
042090	Filter Housing and Filter	Height 230mm Diameter 200mm (excludes port protusion)	1
160540	Replacement Filter	-	1

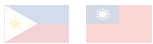

## SUCTION ACCESSORIES

### HEPA H14 Filter – 5-8 Surgeries

Filters exhaust suction air prior to releasing to the atmosphere. Recommended when exhaust air has the potential to be released to areas accessible by people. Suitable for Turbo SMART and selected dry suction units, please contact Cattani customer service team for suitable recommendations.

- Filter should be replaced approximately every 12 months
- Filters 188m<sup>3</sup>/h
- 63mm port connection (refer hose connection page for exhaust hoses)



Order Number	Description	Size	Pack Qty
042092	Filter Housing and Filter (Tandem Turbo SMART & Tandem Turbo SMART Cube)	Height 460mm Diameter 200mm (excludes port protusion)	1
160541	Replacement Filter	-	1

### Password Upgrade – Turbo SMART A to B

Increase the capacity of your serviceable dental chairs through the use of the Cattani password upgrade. Simply entered on the keypad of the suction system and you are ready to go. That's SMART, that's Cattani.

Suitable to upgrade:

- Turbo SMART A to Turbo SMART B
- Turbo SMART Cube A to Turbo SMART Cube B

To streamline order process please provide:

1. Serial Number found on I.D. Label on chassis
2. Generated Code found on Control Panel



Order Number	Description
035500	Turbo SMART Password Upgrade (A to B)

PLEASE NOTE: Refunds/returns are NOT available on password upgrades once ordered from Cattani Italy.

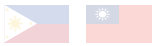

## SUCTION ACCESSORIES

### Micro SMART Series – ISO 6 Hydrocyclone Amalgam Retention Retrofit Kit

Upgrade your Micro SMART to include amalgam retention.

- Flow Rates – Min 0.5 l/min | Max 5.5 l/min

To streamline order process please provide:

1. Serial Number found on I.D. Label on chassis

Order Number	Description	Pack Qty
043383	Micro SMART Amalgam Retrofit Kit	1
043382	Micro SMART CUBE Amalgam Retrofit Kit	1



### Turbo SMART Series – ISO 18 Hydrocyclone Amalgam Retention Retrofit Kit

Upgrade your Turbo SMART to include amalgam retention.

- Flow Rates – Min 0.5 l/min | Max 18 l/min

To streamline order process please provide:

1. Serial Number found on I.D. Label on chassis

Order Number	Description	Pack Qty
043391	Turbo SMART Amalgam Retrofit Kit (Detachable keypad version)	1
043380	Turbo SMART Amalgam Retrofit Kit (Gen 3)	1
043381	Turbo SMART CUBE Amalgam Retrofit Kit	1



### Replacement Amalgam Containers – Smart Suction

Order Number	Description	Pack Qty
043132	ISO 6 Micro SMART and Micro SMART CUBE Amalgam Container	1
043135	ISO 18 Turbo SMART and Turbo SMART CUBE Amalgam Container	1
043138	ISO 60 Maxi SMART Amalgam Container	1
043130	ISO 60 Modular Amalgam Container	1



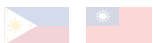

## SUCTION SERVICE KITS

### Minor Service Parts

Order Number	Description	Pack Qty
C-215956	Micro SMART inlet filter o-ring	1
C-211974	Turbo SMART inlet filter o-ring	1
C-215986	Maxi SMART inlet filter o-ring	1

### Intermediate Service Kits

Order Number	Description	Pack Qty
C-MR60SK	Micro SMART and Micro SMART CUBE Intermediate Service Kit – ISO 6 Hydrocyclone	1
C-1H00SK	Turbo SMART and Turbo SMART CUBE Intermediate Service Kit – ISO 18 Hydrocyclone	1
C-043390SK	Maxi SMART Intermediate Service Kit – ISO 60 Hydrocyclone	1

### Major Service Kits

Order Number	Description
C-MSMSK0	Micro SMART Major Service Kit – Includes: C-025401-SK Separator Kit C-014057-SK Blower Kit and C-MSIHSK Internal Hose Kit
C-MSCMSK	Micro SMART CUBE Major Service Kit – Includes: C-025401-SK Separator Kit, C-017500-SK Blower Kit and C-MSCIH0-SK Internal Hose Kit
C-TSMSK0	Turbo SMART Major Service Kit – Includes: C-0034MS-3SK Separator Kit, C-1M0000-SK Blower Kit and C-TSIHSK Internal Hose Kit
C-TSCMSK	Turbo SMART Cube Major Service Kit – Includes: C-0034MS-3SK Separator Kit, C-014095-SK Blower Kit and C-TSCIH0-SK Internal Hose Kit
C-TS2VMSK0	Turbo SMART 2V – Major Service Kit – Includes: C-0034MS-3SK Separator Kit, C-019164-SK Blower Kit and C-TS2VIH-SK Internal Hose Kit
C-MAXIMSK	Maxi SMART Major Service Kit – Includes: C-025408-SK Separator Kit, C-091655-SK Blower Kit and C-MXIHSK Internal Hose Kit



Intermediate Service Kit



Separator Major Service Kit



Blower Major Service Kit

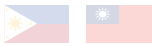

## SUCTION SERVICE KITS

### Separator Major Service Kits

Order Number	Description	Pack Qty
C-025401SK	Micro SMART and Micro SMART CUBE Separator Major Service Kit	1
C-0034MS3SK	Turbo SMART, Turbo SMART CUBE, Turbo SMART 2V Separator Major Service Kit	1
C-025408SK	Maxi SMART Separator Major Service Kit	1

### Blower Major Service Kits

Order Number	Description	Pack Qty
C-014057SK	Micro SMART Blower (U.J. 40) Major Service Kit	1
C-017500SK	Micro SMART CUBE Blower (U.J. 25) Major Service Kit	1
C-1M0000SK	Turbo SMART Blower (U.J. 75) Major Service Kit	1
C-014095SK	Turbo SMART CUBE Blower (U.J.40) Major Service Kit	1
C-019164SK	Turbo SMART 2V Blower (U.J. 75 2V) Major Service Kit	1
C-091655SK	Maxi SMART Blower (M.J.2V) Major Service Kit	1

### Internal Hose Service Kits

Order Number	Description	Pack Qty
C-MSIHSK	Micro SMART Internal Hose Kit	1
C-MSCIH0-SK	Micro SMART CUBE Internal Hose Kit	1
C-TSIHSK	Turbo SMART Internal Hose Kit	1
C-TSCIH0-SK	Turbo SMART Cube Internal Hose Kit	1
C-TS2VIH-SK	Turbo SMART 2V Internal Hose Kit	1
C-MXIHSK	Maxi SMART Internal Hose Kit	1

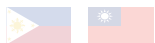

## SUCTION SPARE PARTS

### Accessory Kits for Dry Suction Motors

020240	Accessories For Uni-Jet 75
191250	(1x) Silencer for Uni-Jet Motor
211520	(1x) Silencer Tube for Uni-Jet
250000	(4x) Blower support mounts (M5 15X20)
250141	(8x) M5 Nut
250703	(8x) M5 Flat Washer
250722	(8x) M5 Spring Washer
020611	Accessories For Tecno-Jet
250024	(4x) Blower support mounts (M8 39X26)
160682	(1x) Vacuum Relief Valve for Tecno-Jet (0.75kW)
191280	(1x) Silencer for Tecno-Jet + Non-Return Valve
250142	(4x) M8 Nut
250732	(4x) M8 Flat Washer
250720	(4x) M8 Spring Washer
041040	(2mtrs) Black Spiral Tubing
020831	Accessories For Flux-Jet (1.1kW)
250024	(4x) Blower support mounts (M8 39X26)
160652	(1x) Vacuum Relief Valve for Flux-Jet (1.1kW)
191278	(1x) Silencer for Flux-Jet + Non-Return Valve
230106	(1mtr) 50mm Grey Spiral Tubing
230111	(1mtr) 50mm Heat Resistant Exhaust Tubing
250142	(4x) M8 Nut
250701	(4x) M8 Flat Washer
250720	(4x) M8 Spring Washer
020832	Accessories For Flux-Jet 1.5kW
250024	(4x) Blower support mounts (M8 39X26)
160680	(1x) Vacuum Relief Valve for Flux-Jet (1.5kW)
191278	(1x) Silencer for Flux-Jet + Non-Return Valve
230106	(1mtr) 50mm Grey Spiral Tubing
230111	(1mtr) 50mm Heat Resistant Exhaust Tubing
250142	(4x) M8 Nut
250701	(4x) M8 Flat Washer
250720	(4x) M8 Spring Washer



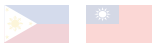

## SUCTION SPARE PARTS

021040	Accessories For Medio-Jet	
250024	(4x)	Blower support mounts (M8 39X26)
160692	(1x)	Vacuum Relief Valve for Medio-Jet
191552	(1x)	2" Non-Return Flap Valve (Threaded Flange)
250142	(4x)	M8 Nut
250732	(4x)	M8 Flat Washer
250720	(4x)	M8 Spring Washer
230149	(1mtr)	60mm Heat Resistant Exhaust Tubing
230108	(1mtr)	60mm Grey Spiral Tubing

021100	Accessories For Maxi-Jet 2S	
250024	(3x)	Blower support mounts (M8 39X26)
160683	(1x)	Vacuum Relief Valve for Maxi-Jet 2S
191275	(1x)	Silencer for Maxi-Jet 2S + Non-Return Valve
250142	(3x)	M8 Nut
250732	(3x)	M8 Flat Washer
250720	(3x)	M8 Spring Washer

## SMART Suction Complete Filter (Element and Housing)

Order Number	Description	Pack Qty
201547	Micro SMART and Micro SMART CUBE	1
201544	Turbo SMART, Turbo SMART CUBE and Turbo SMART 2V	1
201543	Maxi SMART	1



## Miscellaneous

Order Number	Size	Pack Qty
182576	Switch for black control panel – Turbo SMART	1
186485	Cooling Fan for Turbo SMART and Micro SMART	1

## Aspi-Jet

Order Number	Size	Pack Qty
202000	Aspi-Jet Door Handle	1
210720	Rubber Elbow	1
201071	Canister Top – Aspi-Jet 6	1
250662	Castors – Aspi-Jet 6, 7, 8 and 9	1

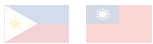

## SUCTION SPARE PARTS

### Inlet Filter Aspi-Jet 6, 7, 8, 9 and Maxi-Canister Separator

Order Number	Size	Pack Qty
041070	Inlet Filter	1



### Filter – Inline Complete (Turbo-Jet 1 and 2 Modular)

Inline filter with 25mm port connections (includes inlet filter)

Order Number	Description	Pack Qty
041080	Inlet Filter	1



### Filter Element for Inline Filter

Order Number	Description	Pack Qty
240317	Filter element	1



### Filter Element for Aspi-Jet Range and Manual Tip Support

Order Number	Description	Pack Qty
041055	Filter element	1



### Air Filter – Aspi-Jet

Order Number	Description	Pack Qty
045060	Air filter	1



### Filter for Pneumatic Tip Support (0055)

Order Number	Description	Pack Qty
201515	Filter element for all pneumatic tip support units	1



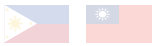

## SUCTION SPARE PARTS

### Filter for Pneumatic Manifold

**Order Number**

201513



### Mono-Jet Drain Pump – Complete

**Order Number**

150440



### Drain Pump and Housing for Continuous Suction Separator

**Order Number**

020935



### Drain Pump Only for Continuous Suction Separator

**Order Number**

150451



### Drain Pump for Aspi-Jet 7, 8 and 9

**Order Number**

150400



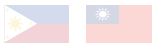

## SUCTION SPARE PARTS

### Elbow Hose Connectors

32mm I.D. female coupling to tapered spigot for flexible suction hose.  
25mm (C-3923B0) 30mm (C-3923A0)

Order Number	Description	Pack Qty
200435	25MM	Single
200440	30MM	Single 8



### Straight Hose Connectors

32mm I.D. female coupling to tapered spigot for flexible suction hose.  
20mm (C-3922C0) 25mm (C-3922B0) 30mm (C-3922A0)

Order Number	Description	Pack Qty
200443	20MM	Single
200450	25MM	Single
200460	30MM	Single



### Hose Connector for Motorised Suction Isolation Valve

Fits into the motorised suction isolation valve with tapered spigot for flexible suction hose. 30mm (C-110800) 40mm (C-110840)

Order Number	Description
200420	30MM
202524	40MM



### Coupling Connector – 32mm

32mm O.D. male joining coupling with O-rings

Order Number	Pack Qty
200205	Single



### Mounted Connectors – Flange fitting with Captive Nuts

Order Number	Description
200430	2 Hose Tip Support (0011B) & Aspi-Jets
202512	Turbo-Jet 1 & 2 Modular In Cover



### Adaptor for EP Suction Isolating Valve

Reduction bush – glues into 40mm DWV pipe (pipe may need to be heated to fit the bush). Reduces internal diameter to 32mm to accept EP suction isolation valve or coupling connector – 32mm (C-0040D0).

Order Number	Pack Qty
F-AEP400	Single



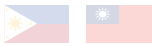

## SUCTION SPARE PARTS

### Control Panels

Order Number	Description
023768	Micro SMART Gen 3 Wi-Fi Control Panel
023766	Micro SMART Cube Control Panel (Metal)
023752	Turbo SMART Gen 3C Wi-Fi Control Panel
023753	Turbo SMART Cube Wi-Fi Control Panel

### Capacitors

Order Number	Description
189106	10 $\mu$ F Capacitor Metal
189115	20 $\mu$ F Capacitor C87.0 "UL" Metal with 150mm Cable
189116	40 $\mu$ F Capacitor C87.0 "UL" Metal with 350mm Cable
189148	55 $\mu$ F Capacitor C87.0 "UL" Metal with 150mm Cable

### Centrifuge

Order Number	Description
025410	HP Type 1 Phase
025411	HP Type 3 Phase
025401	Micro SMART
025408	Maxi SMART 3 Phase
025245	T1/T2 Separator 1 Phase

### PCBs

Order Number	Description
181170	AC48B Turbo-Jet 1 And 2, Tecno and 2V, Turbo-Flux
180921	AC15 Aspi-Jet 6
181271	AC45 Continuous Suction Separator
180917	AC13 Uni-Jet in Box
180971	AC14B Maxi Canister – Single Surgery
180992	AC23 EP Valve
020943	AC25 Mini Canister – Old Style
020939	AC29 Single Surgery Control
181157	AC33 Spittoon Valve C021960
181150	AC58 Micro Centrifuge/Universal Compact Separator
180993	AC5455 Hydrocyclone Level Control for Turbo-Jet Modular Range
185032	Mini Separator Probes 180 Degrees
185033	Round for Top of Mini Canister 90 Degrees

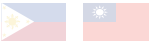

## SUCTION SPARE PARTS

### Micro SMART Separator

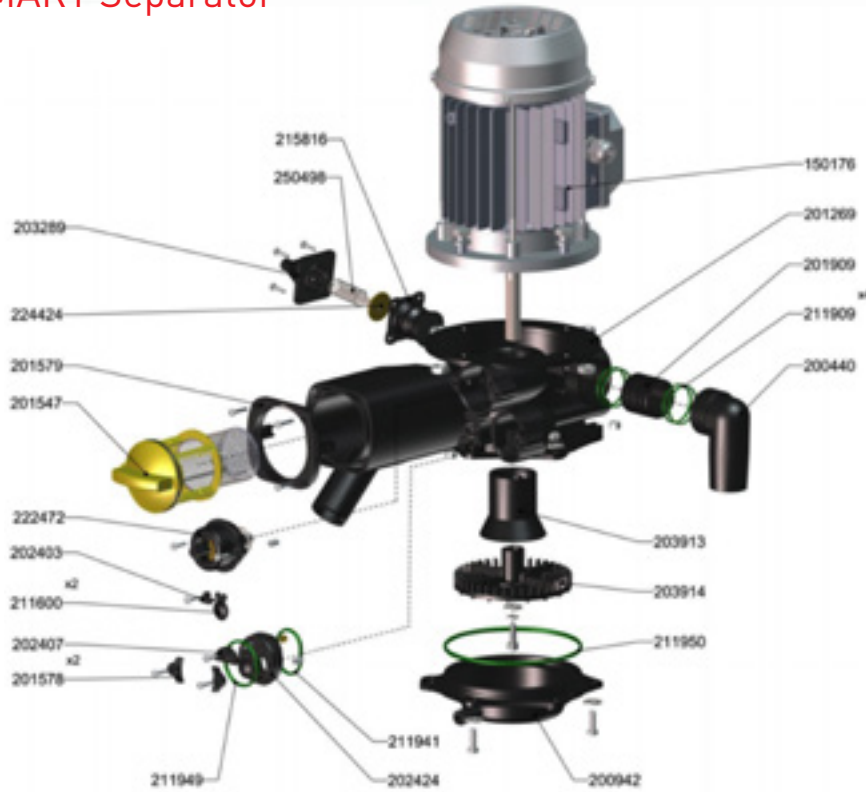

Order Number	Description
203289	Cover – Pressure Valve Turbo SMART
222472	Valve on Micro SMART Separator
202403	Clip for Micro Centrifuge Flap Valve
211600	Non Return Flap Valve
202407	Micro SMART/Cube Centrifuge Holding Plate X Non Return Flap
201578	Holding Bracket for Waste Outlet – Micro SMART
211941	O-ring
215816	Diaphragm for Turbo SMART Valve
250498	Spring on Turbo SMART Separator Valve
211941	O-ring
202424	Non Return Valve Body For Micro SMART Centrifuge
201909	Connector
211909	O-ring for Connectors Sep Top 0039A
200440	Elbow 30mm – Single
203913	Cylindrical Fan – Micro SMART
203914	Pumping Disc – Micro SMART
211950	O-ring for Micro SMART Centrifuge Base



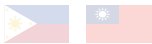

## SUCTION SPARE PARTS

### Turbo SMART Separator

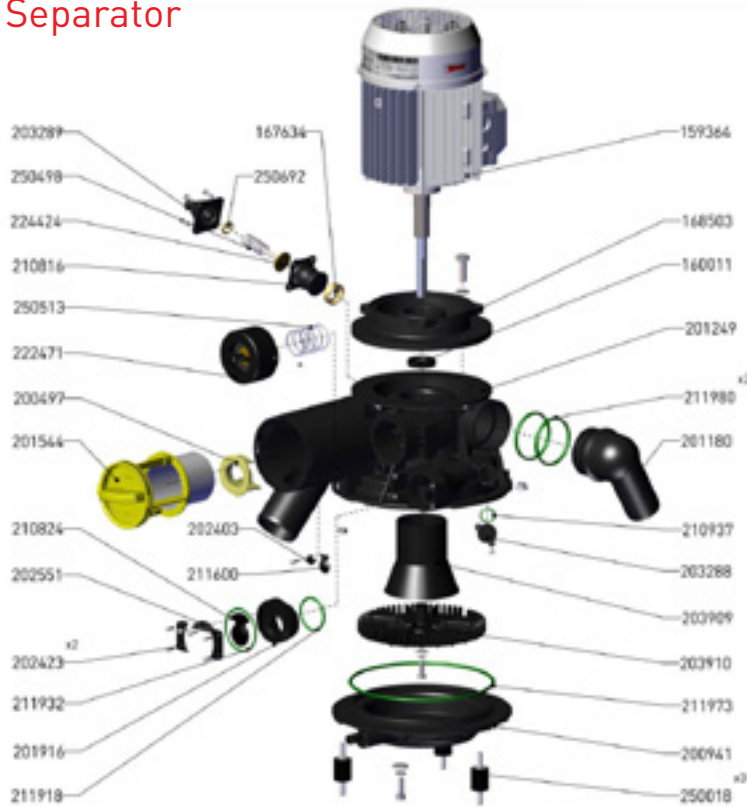

Order Number	Description
203289	Cover – Pressure Valve Turbo SMART
250498	Spring on Turbo SMART Separator Valve
210816	Diaphragm for Turbo SMART Valve
250513	Spring for Valve on SMART Separator
222471	Valve on SMART Separator
201544	Inlet Filter & Housing X Turbo SMART
202403	Clip for Micro Centrifuge Flap Valve
211600	Non Return Flap Valve
210824	Non-Return Flap Valve
202551	SMART Centrifuge Holding Plate X Non Return Flap
202423	Retaining Plate – SMART Waste Outlet
211932	O-ring – Waste Outlet (Outer) – SMART Separator
201916	Non Return Valve Body for HP Centrifuge
211918	O-ring – Waste Outlet (Inner) – SMART Separator
168503	Mid Plate Casting for Turbo SMART Separator
160011	Oil Seal for HP Centrifuge
211980	O-ring for Turbo SMART Centrifuge Dry Outlet Elbow
201180	Elbow for SMART Centrifuge 40mm
210937	O-ring
203288	HP Centrifuge Bypass Valve Inspect Plate
203909	Cone for HP Type Centrifuge
203910	Impeller Turbo SMART/HP Type Centrifuge
211973	O-ring for SMART Centrifuge Base
200941	Turbo SMART Centrifuge Base
250018	Motor Mount for SMART Centrifuge

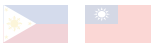

# SUCTION SPARE PARTS

## ISO 6

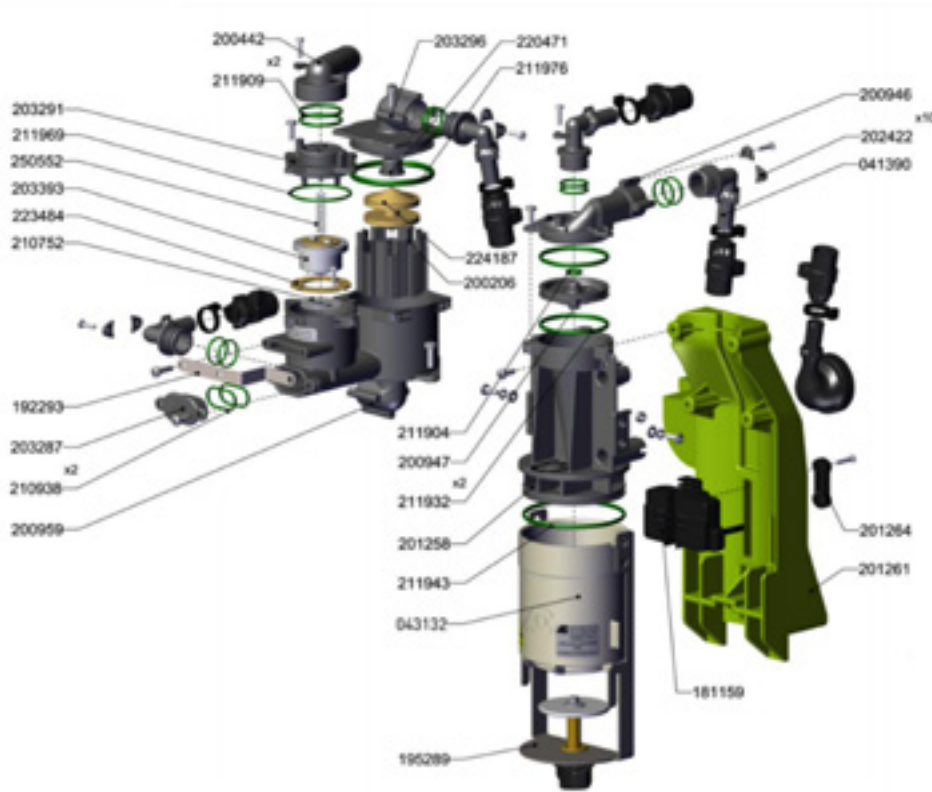

Order Number	Description
203291	Top Cover for Waste Outlet ISO 6 & 8
211969	O-ring
250552	Spring for ISO 18 Waste Non Return Valve
203393	Bob Assembly for ISO18 Waste Non Return Valve
223484	Retainer – Rubber Seat – Non Return Valve ISO 18
210752	C – Rubber Seat – Non Return Valve ISO 18
210938	O-ring
200442	Elbow for ISO 18 on SMART
211909	O-ring
211976	O-ring
224187	Brass Valve for Hydrocyclone – M/SMART And M/SMART Cube
200206	Support Cage for Hydrocyclone – Micro SMART/ Micro SMART
211904	O-ring – Cyclone 6 Exit
211932	O-ring – Waste Outlet (Outer) – SMART Separator
211943	O-ring for ISO 18 & ISO 5.5 Cup – Single
043132	Container – ISO 5.5 Amalgam Trap – Micro SMART (Ecocycle Only)
195289	ISO 6 Cup Bracket Complete
041390	Hose Assembly – ISO 6 Hydrocyclone
201264	Holding Piece for ISO-5.5 Sensor Mount
181159	Amalgam Level Sensor For Micro SMART



## SUCTION SPARE PARTS

### ISO 18

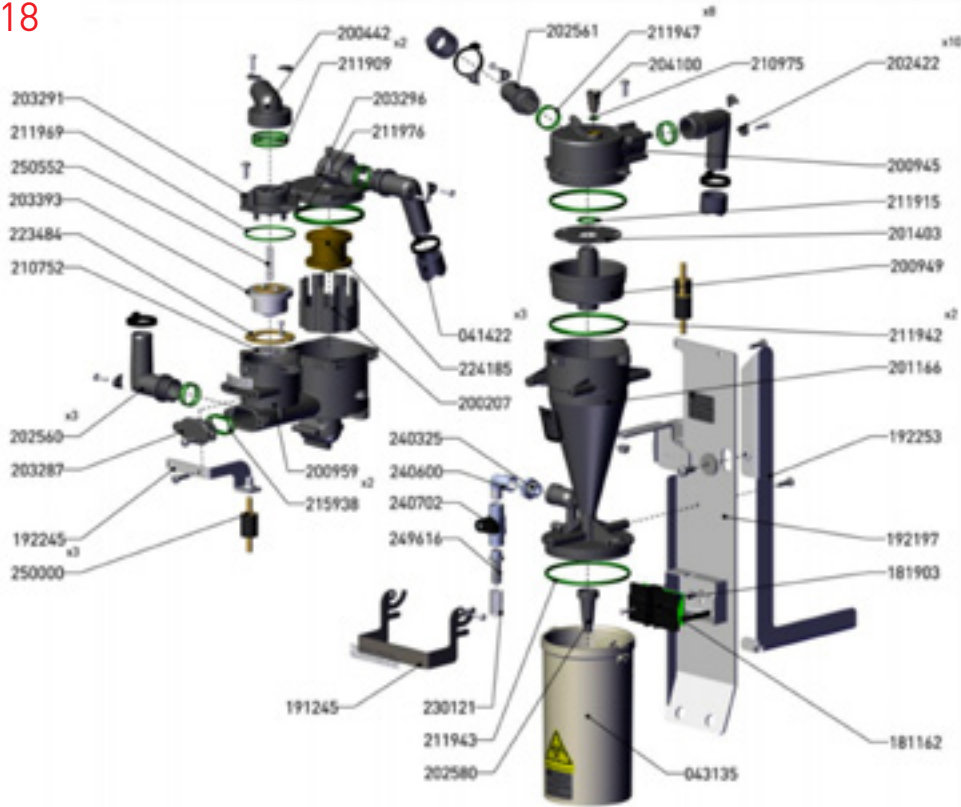

Order Number	Description
203291	Top Cover for Waste Outlet ISO 6 & 8
211969	O-ring
250552	Spring For ISO 18 Waste Non Return Valve
203393	Bob Assembly for ISO18 Waste Non Return Valve
223484	Retainer - Rubber Seat - Non Return Valve ISO 18
210752	Rubber Seat - Non Return Valve ISO 18
202560	ISO-18 Elbow
250000	Blower Supprt Mounts - Micro SMART Cube
200442	C - Elbow for ISO 18 On SMART
211909	O-ring
211976	O-ring
200959	ISO 6 & 18 Recycle Chamber Housing
215938	O-ring
041422	Tube 17.5mm Dark Grey X Turbo SMART
224185	Bypass Valve 1in for ISO 18
200207	Support Cage for 1in Bypass Valve (ISO 18)
240325	Small Metal Connector for ISO-18 Drain
240600	Small Metal Elbow for ISO-18 Drain
240702	Small Metal Tap for ISO-18 Drain
249616	Metal Connector for ISO-18 Drain Valve
230121	Drain Tube for Drip Tray - Micro Sart Cube
211943	O-ring for ISO 18 & ISO 5.5 Cup - Single
202580	ISO-18 Cyclone Tip
202561	ISO-18 Straight Connector
211947	O-ring for ISO-18 Hose Connector
210975	O-ring for ISO-18 Breather Screw
211915	O-ring for ISO 18 Cyclone Exit
211942	O-ring for ISO-18 Body
201166	ISO-18 Cyclone Body
192197	Supporting Bracket for Amalgam Cup Sensor PCB (Gen 3C)
181162	Amalgam Cup Sensor PCB (Gen 3C Compatible)
043135	Container Tall - ISO 18 l/min Amalgam Trap (CMA Eco Only)
224185	Bypass Valve 1in for ISO 18

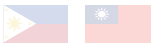

# CONSUMABLES

## WHY MAGNOLIA?

As dental care professionals, it is important to apply the appropriate product to your suction equipment to ensure not only the health of your machine, but also as part of your infection control for the safety of staff and patients.



The Magnolia disinfectant range has been specifically developed by Cattani for use with Cattani suction systems. The use of products and procedures outside of manufacturer recommendations can allow bacterial layers to build up. This can impede suction, compromising performance and ultimately damaging machines and systems.

Failure to clean, disinfect or maintain systems methodically as per the manufacturer's recommendations may affect the product warranty.

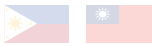

## MAGNOLIA PRODUCTS

### **PULI-JET GENTLE 2.0 – NON-FOAMING DENTAL DISINFECTANT**

At Cattani, we offer the PULI-JET Gentle 2.0 dental disinfectant from our Magnolia range, registered as an antimicrobial solution specifically made to disinfect dental medical devices. This is a non-foaming commercial grade disinfectant designed to clean and disinfect the dental suction lines.

### **PULSE CLEANER – MAXIMISES DISINFECTANT ASPIRATION THROUGH THE SUCTION SYSTEM**

The Pulse Cleaner automatically aspirates PULI-JET Gentle 2.0 disinfectant solution through the suction system by creating air and fluid turbulence, evenly and widely distributing the disinfectant for the most effective cleaning and protection.

### **LUBRI-JET SILICONE LUBRICANT DROPS – EASY CARE FOR O-RINGS AND SEALS**

LUBRI-JET is a silicone-based lubricant supplied in a handy dropper bottle, ideal for lubricating rubber O-rings and seals, which increases their lifespan.

Each single pack of LUBRI-JET contains four 30ml bottles.

### **ANTIFOAMING DISINFECTANT TABLETS – CONTINUOUS DISINFECTION ALL DAY**

Antifoaming Disinfectant Tablets manage the foam that can occur through surgical treatments that have a large amount of dense liquids such as blood, mucus, and thick saliva. The tablet also has a slow-release capability, so that it continuously disinfects the suction lines throughout the entire working day.

Each pack contains 50 tablets, with one required per surgery per day.



**AT CATTANI, WE DON'T JUST CLEAN. WE DISINFECT.**



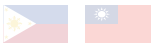

# PULI-JET GENTLE 2.0

## Non-foaming disinfectant for dental suction systems

**PULI-JET Gentle 2.0** is an antimicrobial solution from our *Magnolia* range, specifically made to disinfect dental suction devices, known for its easy-to-remember single dilution disinfecting procedure.

- Phenol free
- Aldehyde free

No alternating schedules, products, or shock treatments are needed.

Each bottle makes 33 doses. Available in 1-litre bottles (30ml of PULI-JET Gentle 2.0 to 2.5 litres of warm water).

### ONE DISINFECTANT, ONE DILUTION, ONCE A DAY



Order Number	Size
060900	4 Pack



**SUCTION UNIT MAINTENANCE**  
Point your smartphone camera at this QR code to view our short instructional videos



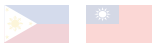

## CONSUMABLES

### Antifoaming Disinfectant Tablets

Reduces foam that occur through surgical treatments that have a large amount of dense liquids such as blood and mucus, as well as continuously disinfecting the suction lines through the working day.

Each pack contains 50 tablets, with one required per surgery per day.



Order Number	Size
040826	Single

### Pulse Cleaner

Automatically aspirates PULI-JET Gentle 2.0 disinfectant solution through the suction system by creating air and fluid turbulence, evenly and widely distributing the disinfectant for the most effective cleaning and protection.



Order Number	Size
040720	Single

### Reducer Adaptor For Pulse Cleaner

Order Number	Size
040398	Single



### Plunger For Pulse Cleaner

Order Number	Size
201846	Single



### LUBRI-JET Silicone Lubricant Drops 30ml

A silicone-based lubricant supplied in a handy dropper bottle, ideal for lubricating rubber O-rings and seals, which increases their lifespan.

Each pack contains 4 x 30ml bottles.

Order Number	Size
040727	Single Box (4 x 30ml)



### Antifoam Liquid

High efficacy antifoam silicone liquid for larger dental facilities. Reduces foam that occur through surgical treatments that have a large amount of dense liquids such as blood and mucus.

Order Number	Size
040725	Single



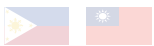

# SELECTION, INSTALLATION, MAINTENANCE AND SERVICE

The pursuit of 100% reliability is what drives Cattani at every level. Our Cattani Blueprints Training Program™ and Cattani After Care Training Program™ cover the essential aspects of selection, installation, ongoing preventative maintenance, and servicing of Cattani equipment for dental clinics.

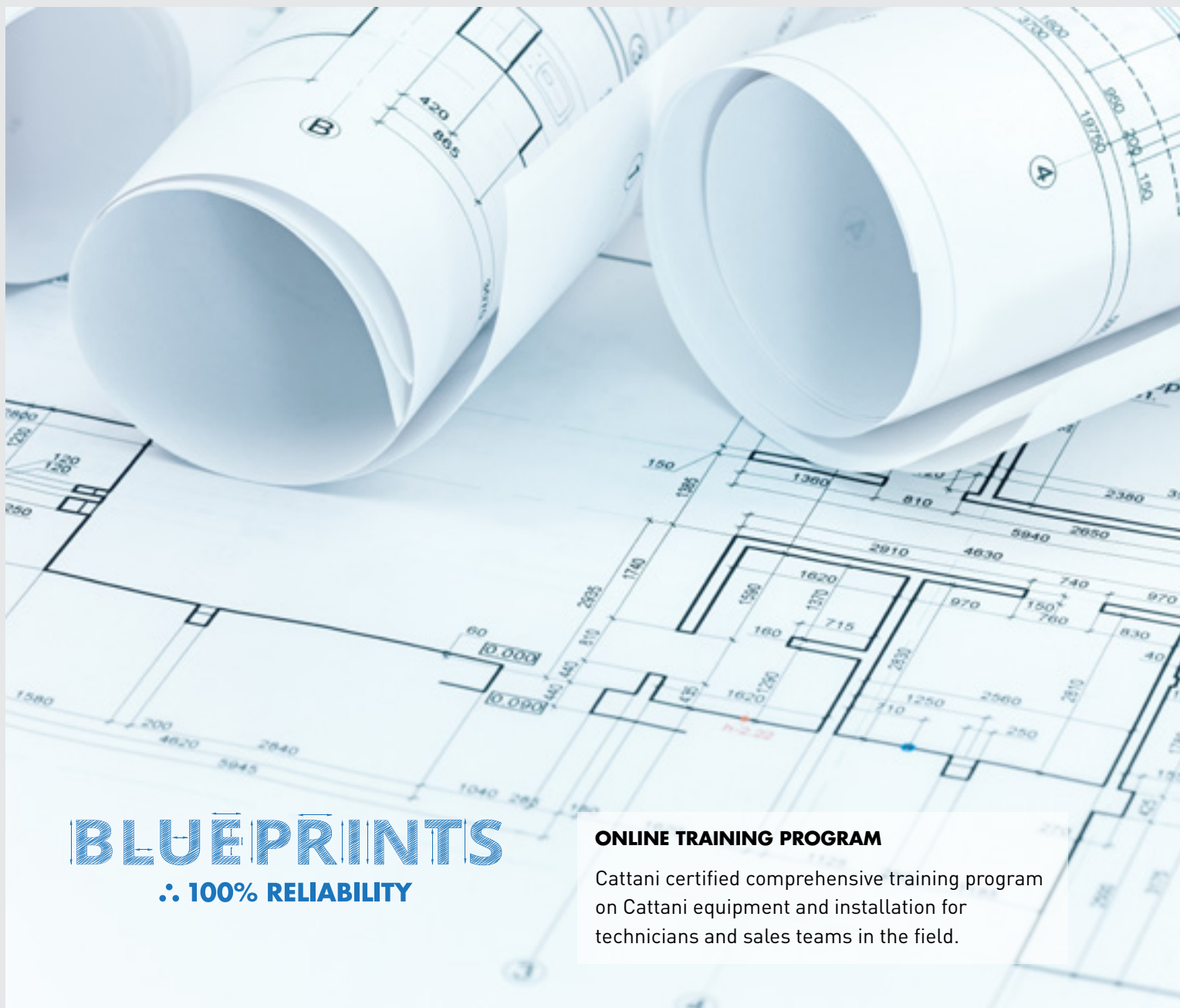

**BLUEPRINTS**  
∴ 100% RELIABILITY

## ONLINE TRAINING PROGRAM

Cattani certified comprehensive training program on Cattani equipment and installation for technicians and sales teams in the field.

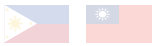

# AFTER CARE

∴ 100% RELIABILITY

## AFTER CARE TRAINING PROGRAM

Comprehensive training program for technicians on everything about servicing your equipment.

## AFTER CARE: PROTECT THE POWER BEHIND YOUR PRACTICE

Cattani Australasia wants equipment owners to get maximum benefit, reliability, and life out of their purchase. To that end, we encourage all end users to follow our daily and weekly maintenance guidelines.

We also urge owners to ensure that their equipment is serviced annually using the After Care Service Kits. With annual servicing and scheduled replacement of wear-prone parts you are protecting the power behind your practice. Your suction unit and compressor will then serve you well for its lifetime, preventing untimely and costly breakdowns; and you know the cost from the beginning.



## VENTILATION GUIDELINES – CONTROLLING THE TEMPERATURE IN YOUR PLANT ROOM

### AIR CONDITIONING

Air conditioning is the best way to maintain the stable temperatures your plant room equipment needs for optimal performance. Modern split systems are the most efficient and affordable. And with a dedicated air conditioner in your plant room, no vents are required, so noise emissions are greatly reduced.

The clinic's central air conditioning system must not include the plant room. Instead the room should have its own dedicated air conditioner. Central systems are designed for human comfort and the thermostat is usually located in reception. It cannot sense the temperature in the plant room, so in winter, for example, it would often be heating the room, even though it generates its own heat.

Recommendations for plant room air conditioning:

- 1-4 surgeries – 2.5 kW
- 4-6 surgeries – 3.5 kW
- 6-8 surgeries – 4.5 kW
- 8-10 surgeries – 5.5 kW

### NOISE REDUCTION OPTIONS

All plant room equipment generates noise, which can irritate dentists, staff and patients. The noise level may also breach council and body corporate regulations. Any noise reduction solution that will cause equipment to overheat is out of the question, so a balance between ventilation and noise reduction needs to be found:

- The plant space can be air conditioned to eliminate the need for vents
- The space may be lined with sound insulation
- Cattani supplies Acoustic Covers for certain models
- Mufflers can be fitted to the suction exhaust outlet
- Fan-forced ventilation vents can be baffled (see below)

### FAN-FORCED VENTILATION

Fan-forced ventilation systems turn over the air in the plant room. Cool air is drawn in while hot air is exhausted via the in-line fan. With this ventilation method we recommend a fan capacity of 150m<sup>3</sup>/hr per 1 kW power rating of your equipment.

There are drawbacks with fan-forced ventilation:

- Noise – the vents needed to allow air to flow through the plant room also allow more noise to escape the room, including extra noise generated by the cooling fans.
- Temperature – an efficient fan-forced ventilation system will only reduce the temperature to 10°C above the incoming air temperature. Also, temperature control is only as consistent as the incoming air temperature.

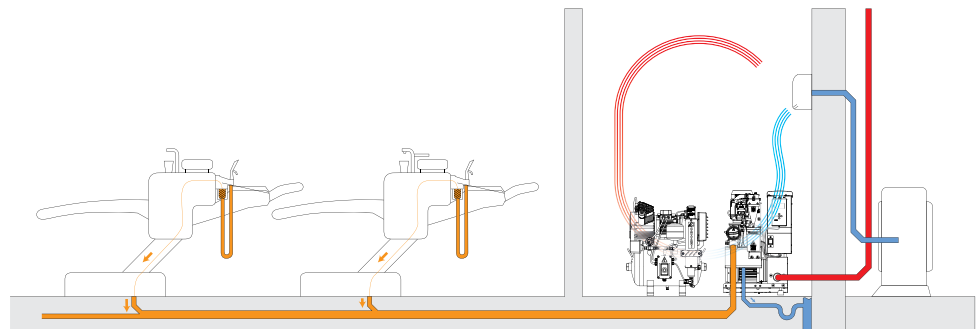

A simple baffle can reduce noise escaping from vents. Essentially, a box with one end open is placed over the vent. Air can pass through but noise is absorbed. The box can be made of materials similar to cabinet doors and ideally should be lined with sound insulation. Ensure that the open end of the box is large enough so that it does not restrict air flow. Restricting air flow will compromise the efficiency of the ventilation system.

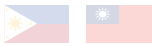

## WHAT YOU NEED TO KNOW

Suction and air supply are the unsung heroes of the dental practice. Without their optimal performance and reliability, work suffers and can even stop, so it is essential that your Cattani equipment is installed correctly.

Your Cattani dealer will discuss with you the various installation options and recommend those that best suit your clinic and environment. The information below is a useful starting point for site requirements, while your installer has the expertise to ensure your set-up produces optimal performance and longevity.

The team at Cattani is also happy to advise you on planning your installation. Call us at +61 3 9484 1120.

### SUCTION SYSTEM ESSENTIALS

The suction piping system uses DWV PVC pipe and connects each dental surgery back to the suction unit in the plant room. The suction unit should be installed on the same floor level or below the level of the dental chairs. It should have a constant fall from the chairs towards the suction unit and cannot include 90° junctions, dips, U-shapes or rises. Termination within the dental surgery is typically at the floor junction box of the dental chair, but is site dependent. The chair manufacturer or installer should be consulted for location details.

Your suction unit will need:

- Suction inlet connection – termination of suction piping that connects to dental surgeries
- Waste connection – sewer drain pipe terminated lower than waste outlet of suction unit
- Exhaust air outlet connection – piping that directs exhaust air to atmosphere outside the building
- Power supply – dedicated electrical power circuit to run the suction unit
- Control switch wiring – switch wiring to connect the dental surgeries to the suction unit

### COMPRESSOR ESSENTIALS

The compressed air piping system is typically copper and connects each dental surgery back to the compressor unit in the plant room. Termination within the dental surgery is typically at the floor junction box of the dental chair, but is site dependent. The chair manufacturer or installer should be consulted for location details.

Your compressor will need:

- Compressed air outlet connection – termination of compressed air piping system that connects to the dental surgeries
- Power supply – dedicated electrical power circuit to run the suction unit
- Waste connection (optional) – sewer connection to allow drainage of compressor condensate

### LOCATION AND ACCESS – WHERE TO POSITION YOUR PLANT ROOM

When designing a new practice, the location of your plant room is an important consideration because proper planning will ensure the most efficient and balanced suction performance. Locating the plant room close to surgeries prevents underperformance caused by excessive pipeline lengths. The plant room must be on the same floor as the dental chairs, or below them. Fluids need to fall to the pump, so if there is a floor below the chairs, like a car park or basement that is accessible and still close to the dental suites above, that location would be ideal for the plant room. Many sites also have air-conditioned plant rooms to protect their investment.

### MAXIMISE YOUR SYSTEM'S PERFORMANCE WITH AN AIR INJECTOR VALVE

Cattani highly recommends the use of an Air Injector Valve with all suction systems. It is best to install one at the time the clinic is constructed but they can also be added later.

Air must flow through the piping in a suction system to help aspirated fluids reach the suction unit. Depending on the site scenario, it is possible that insufficient air will flow through the system. This can lead to fluctuations in performance as fluids pool at the lowest part of the system, with air flow falling below optimal levels. An Air Injector Valve, installed at the end of the pipeline, is an excellent way to compensate for any lack of air volume.



There are two types available:

- Standard Air Injector Valve – a constantly variable unit that allows the flow of small volumes of air over long periods. It is a simple spring-loaded, vacuum-actuated valve, designed to open at the same time that the chairs are in operation.
- Automatic Air Injector Valve – an automated unit that allows the flow of large volumes of air over short periods. This is an electro-pneumatic valve that is actuated by an electrical signal. It is designed to open only when all chairs have ceased operation. With no air flow required from the chairs, the valve allows a large volume of air to be injected into the system without compromising the performance to the chair.

If you are building a new clinic, we strongly recommend that you make provision for an Air Injector Valve to be fitted, even if you don't install it straight away. It is much simpler to install an Air Injector Valve to existing services rather than have to add those services later. To provide for an Air Injector Valve, you need to extend the suction pipeline past the chair furthest from the suction unit, terminating the line at a point higher than the main suction pipe line, in an accessible area like a cabinet, ceiling space, void etc. An additional switch cable between this point and the suction unit is also required. Ensure that the pipe is capped if an Air Injector Valve is not being installed immediately. If a system does not have the extra pipe-work from the start, an Air Injector Valve can be retro-fitted by adding it to the floor junction box of the dental chair. However, the noise generated by the aspirated air can be disruptive.

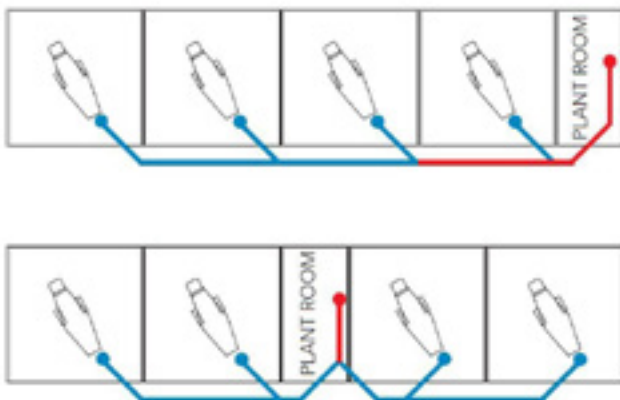

## PIPELINE DESIGN AND LAYOUT

The pipeline needs to facilitate the flow of air and fluids back to the plant room. Pipelines should be designed with a main pipe connected to branches from each dental chair. Large clinics may also require sub-branches. Where possible the piping should take the shortest and straightest route between the plant room and the last dental chair on the line. The diameter of the pipe depends on the number of chairs and the proximity to the plant room: in simple terms, the further from the plant room, the smaller the pipe.

## PIPE SIZE GUIDELINES

Pipe size plays a crucial role in ensuring an even air flow and efficient evacuation of fluids. Suction plumbing requirements based on an average air flow rate of 350l/min per chair are:

- 1-2 chairs – 40mm DWV pipe
- 3-6 chairs – 50mm DWV pipe
- 7-10 chairs – 65mm DWV pipe
- 11-15 chairs – 80mm DWV pipe

## PIPELINE CONFIGURATION GUIDELINES

Bends in the pipeline should never be greater than 45°. If a 90° bend is required, use 2 x 45° bends together in-line. All branches entering a main line must use 45° junctions. Do not use a T-junction when splitting main lines into two branches. Instead, use a 45° Y-junction for the first branch off the main line and 2 x 45° bends for the second.

## PIPELINE RISE AND FALL GUIDELINES

The pipeline should slope constantly towards the suction unit in the plant room. Strictly avoid dips and U-shapes around beams etc to prevent fluids pooling at the lowest point and restricting air flow. If the suction unit is installed on the same floor as the dental chairs, a single vertical rise should be installed just before the unit with the height kept to a minimum. The higher this rise, the greater the risk of fluids creating a wave effect as they try to reach the inlet of the suction unit. This "wave" may cause fluctuating performance at the suction tips.







**Sales and Technical Support:**



**Asia**  
+65 6708 7434  
[www.cattaniaasia.com](http://www.cattaniaasia.com)

Block A-5-6, Oasis Square  
No.2 Jalan PJU 1A/7A, Ara Damansara  
47301 Petaling Jaya, Selangor, Malaysia