

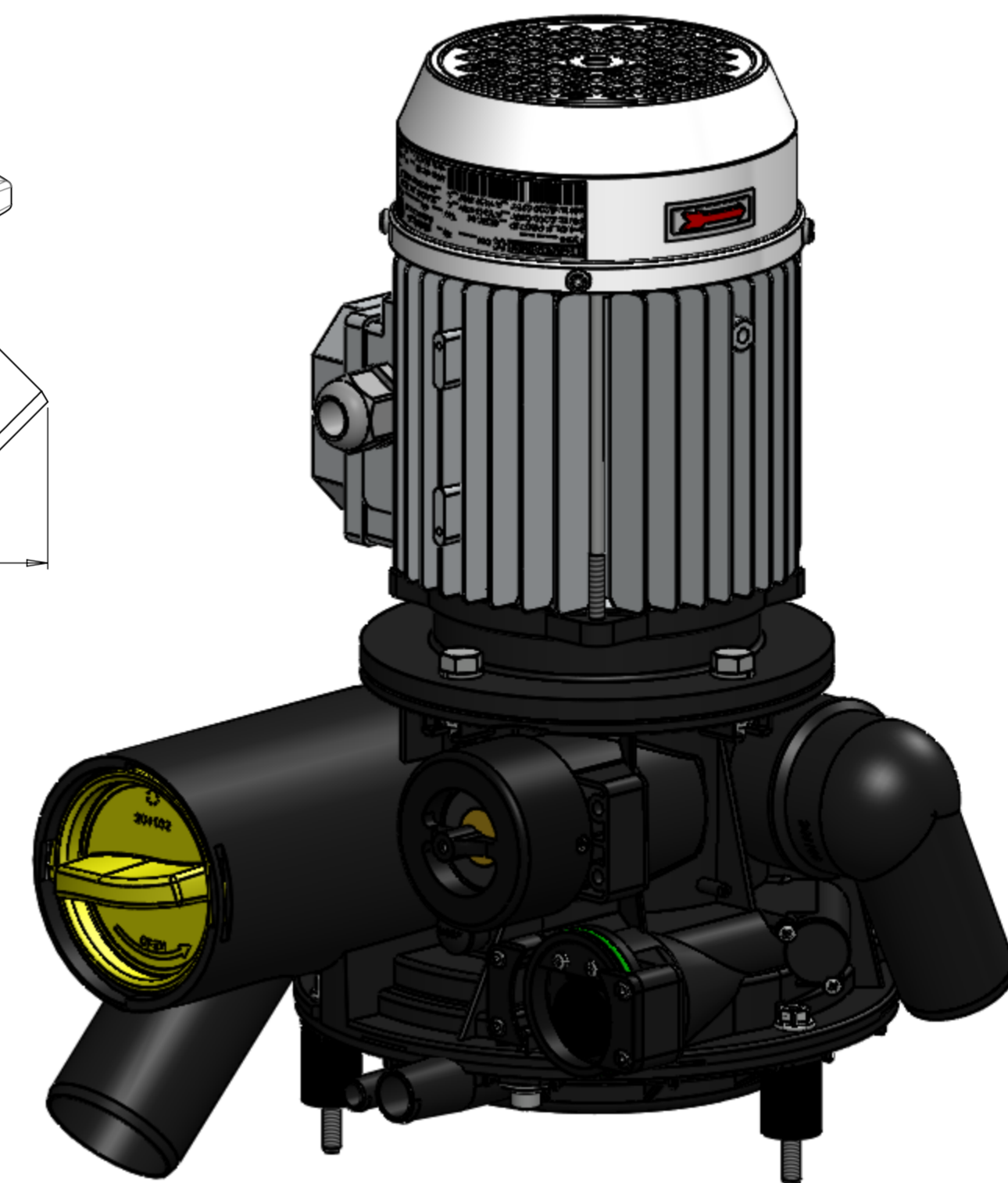

N°	Modifica	Data	Firma

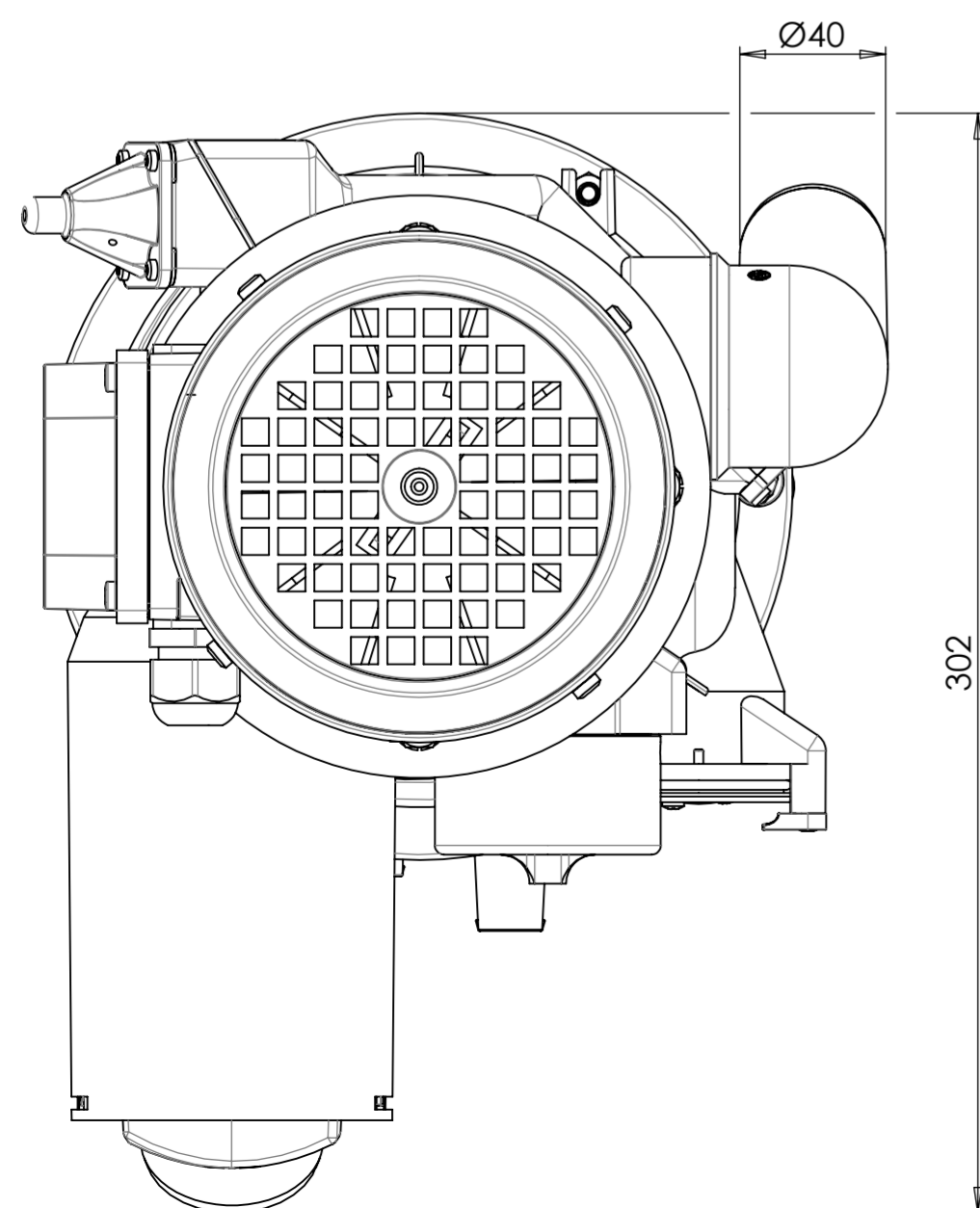
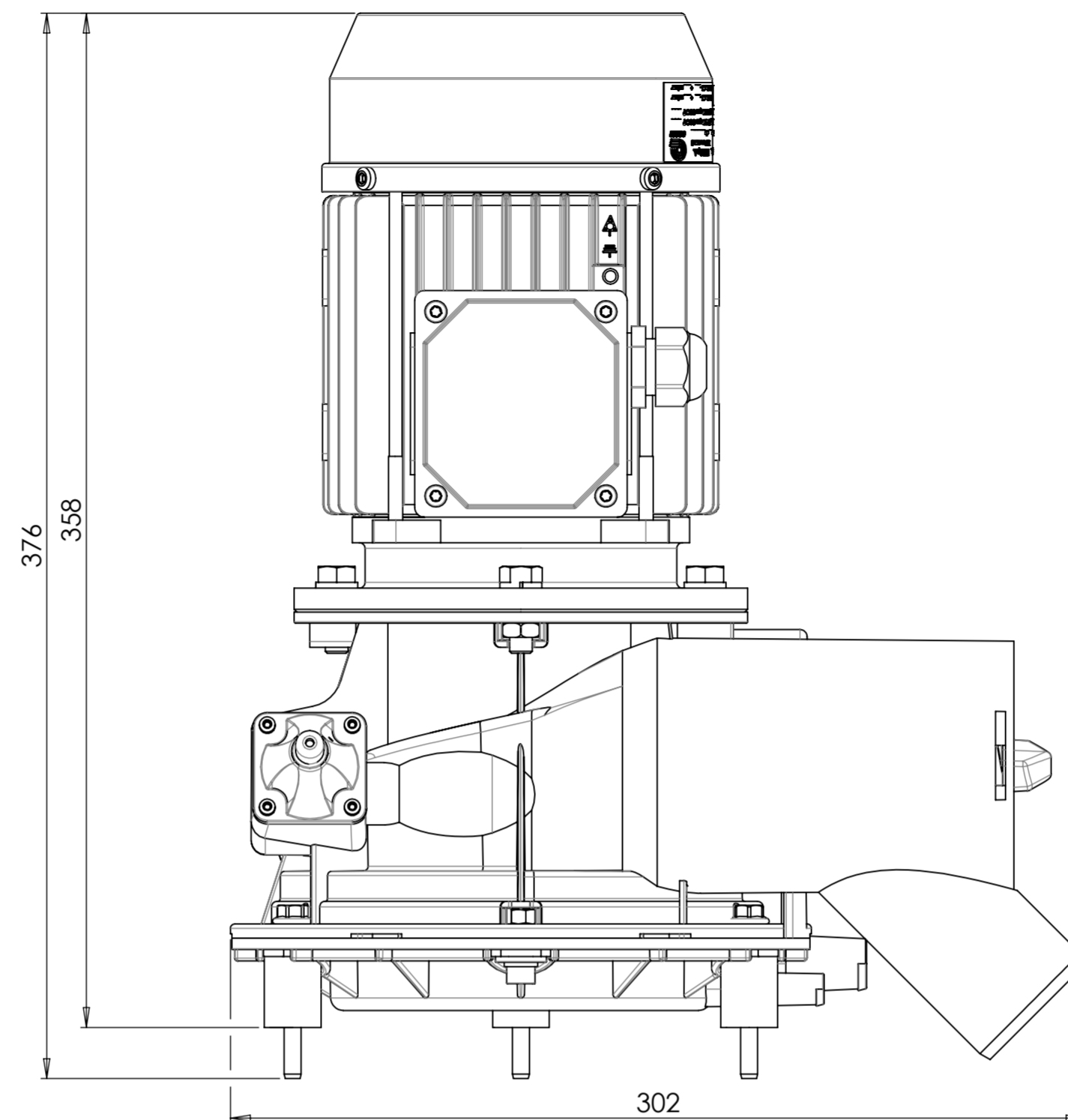
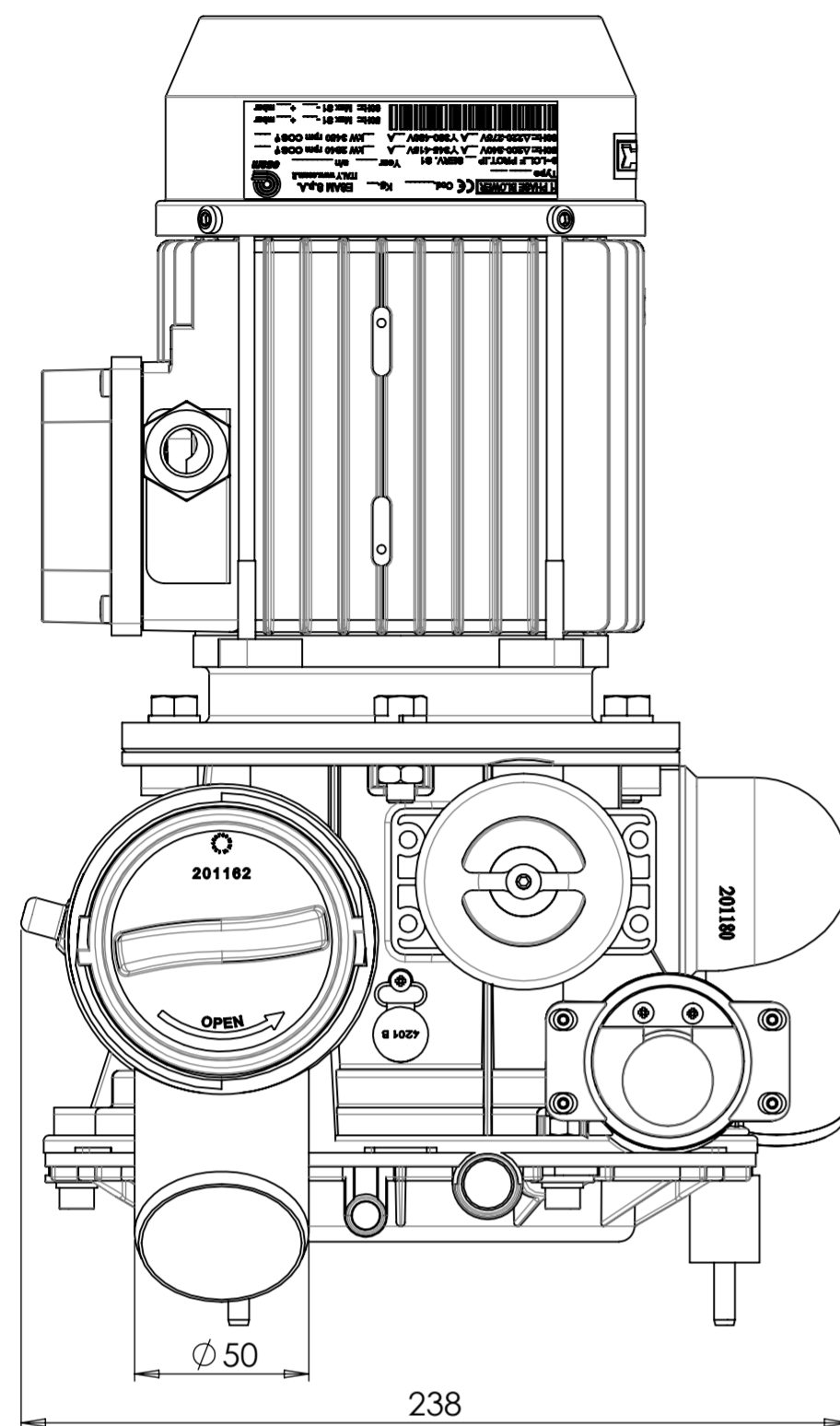
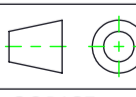

POS.	CODICE	MATERIALE GREZZO - DESCRIZIONE COMPONENTI	Q.TA'	DISEGNO NUMERO		
	DISEGNATO	APPROVATO		Peso-Kg	Modello	
DATA	20/01/2016	20/01/2016				
FIRMA	MORTALI					
 Cattani S.p.A. Via Natta 6/A 43122 Parma - Italy T. +39 0521 607 604 F. +39 0521 607 628 info@cattani.it www.cattani.it			ESEGUIRE LE QUOTE SENZA INDICAZIONE IN CLASSE DI TOLLERANZA <b>FINE</b> SECONDO UNI ISO 2768 DEL 1991 (FORI TOLLERANZA +/- ALBERI TOLLERANZA -) GOLE DI SCARICO PER PARTI DA RETTIFICA SECONDO UNI4386 FORME E/F		SCALA 1:2	
DENOMINAZIONE			CODICE			
SEPAR.CENTR.TURBO-SM.CUBE 230\400V 50Hz			<b>025414</b>			
GRUPPO MACCHINA			DISEGNO NUMERO			
<b>TURBO-SMART</b>			<b>CF06-10-01</b>			